

bosal

**Инструкция
по монтажу тягово-сцепного
устройства шарового типа 1219 Н
для автомобилей
ВАЗ - 1119
“Калина” НВ**

| | |
|--|-----------|
| | 2006 -... |
| | 900 |
| | 50 |
| | 9,1 |



462800,

« - »

18

т. (35363) 7-05-06

факс (35363) 7-13-20

т. (495) 785-66-07

www.bosal-autoflex.ru

| | |
|--------|-------------------------------|
| « - »: | (8182) 22-48-15 |
| " - " | " 8(8442) 98-74-98 |
| " - " | " 8(343) 379-39-89, 373-42-73 |
| " - " | " 8(343) 26-88-308 |
| " - " | " 8(3952) 710-194 |
| " - " | " 8(495) 777-54-59 |
| " - " | " 8(495)745-79-11 |
| " - " | " 8(495) 788-95-97 |
| " - " | " 8(495) 720-51-03 |
| " - " | " 8(3532) 57-99-85 |
| " - " | " 8-905-899-5012 |
| " - " | " 8(383) 291-59-60 |
| " - " | " 8(831) 279-53-24 |
| " - " | " 8(3422) 98-27-20 |
| " - " | " 8(342) 220-87-87 |
| " - " | " 8-927-002-90-06 |
| " - " | " 8(3462) 24-00-44 |
| " - " | " 8(3842) 21-14-76 |
| " - " | " 8-902-940-4151 |
| " - " | " 8(3452) 32-22-12, 41-52-62 |
| " - " | " 8-961-213-0278 |
| " - " | " 8-917-347-1700 |
| " - " | " 8(351) 269-44-75, 900-72-73 |
| " - " | " 8(3512) 773-76-91 |

41.55-2005.

-
-
-
-
-
-
-
-

/ ,

10 1,25 25.

12 30.

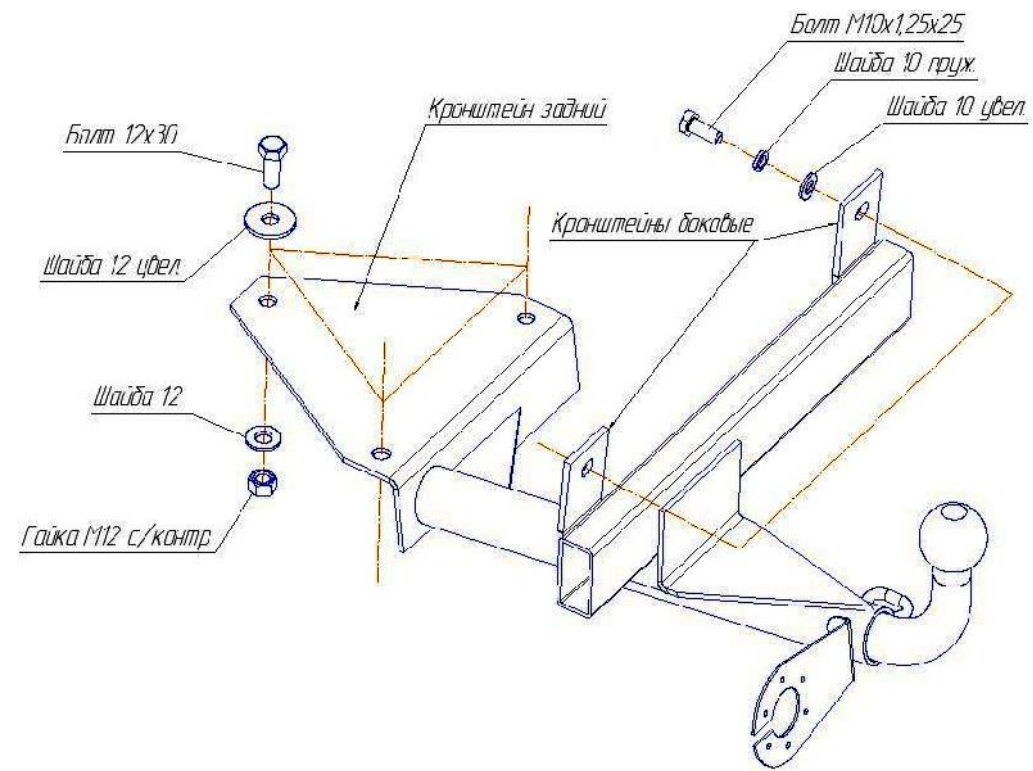

| | | | |
|---|--|--|--|
| | | | |
| 1 | | | |
| 2 | | | |
| 3 | | | |
| 4 | | | |
| 5 | | | |
| 6 | | | |
| 7 | | | |

| | |
|--|-----|
| | |
| | 1 . |
| | 1 . |
| | 1 . |

| | |
|------------|-----|
| | |
| 2 | 1 . |
| 10 1,25 25 | 2 . |
| 12 30 | 3 . |
| 12 (/) | 3 . |
| 10 () | 2 . |
| 10 | 2 . |
| 12 | 7 . |
| 12 () | 3 . |
| | 1 . |
| | 1 . |
| | 1 . |

