

bosal

Инструкция по монтажу тягово-сцепного устройства шарового типа 2633 А для автомобилей **Fiat Albea**

	2003/4...
	1000
	75
	15.85



462800,

« - »

18

./ : (35363) 7-05-06
/ : (35363) 7-13-20
(495) 785-66-07
www.bosal-autoflex.ru

« - »	(8182) 22-48-15
" - "	" 8(8442) 98-74-98
" - "	" 8(343) 379-39-89, 373-42-73
" - "	" 8(343) 26-88-308
" - "	" 8(3952) 710-194
" - "	" 8(495) 777-54-59
" - "	" 8(495) 745-79-11
" - "	" 8(495) 788-95-97
" - "	" 8(495) 720-51-03
" - "	" 8(3532) 57-99-85
" - "	" 8-905-899-5012
" - "	" 8(383) 291-59-60
" - "	" 8(831) 279-53-24
" - "	" 8(3422) 98-27-20
" - "	" 8(342) 220-87-87
" - "	" 8-927-002-90-06
" - "	" 8(3462) 24-00-44
" - "	" 8(3842) 21-14-76
" - "	" 8-902-940-4151
" - "	" 8(3452) 32-22-12, 41-52-62
" - "	" 8-961-213-0278
" - "	" 8-917-347-1700
" - "	" 8(351) 269-44-75, 900-72-73
" - "	" 8(3512) 773-76-91

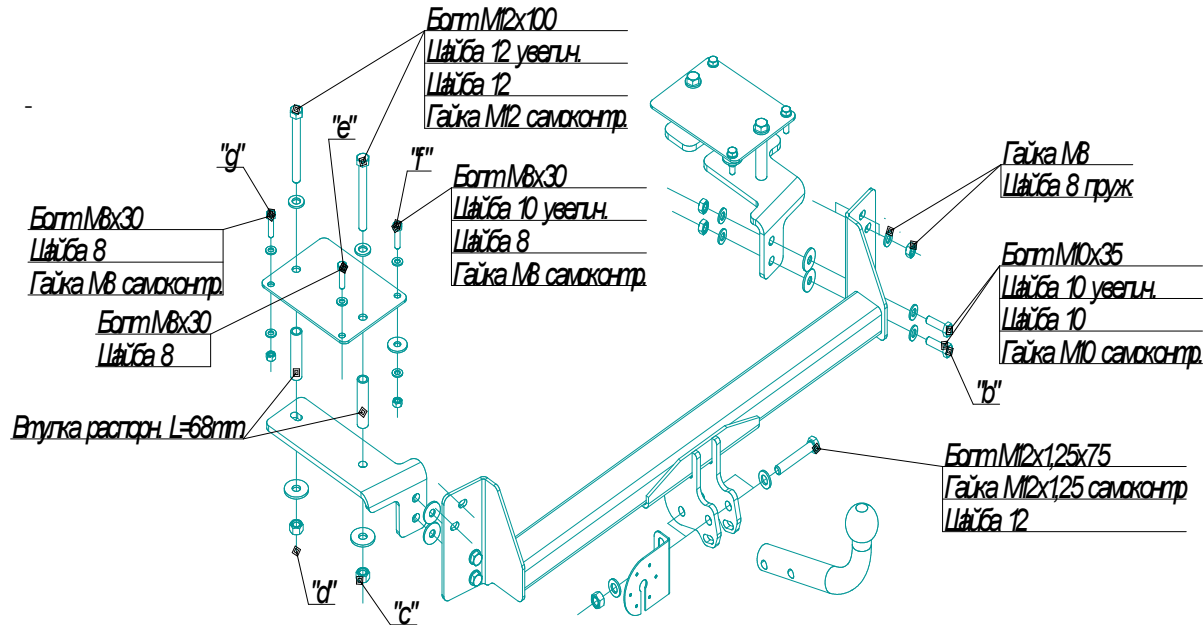

“b” d=10
 “c” “d”.
 d=12.5
) d=18

“a”
 “c” “d”

“b”, “c”, “d”.

“c”.
 “g”, “e”, “f”
 d=8

	1
	1
	1

	3
12 1.25x75	2
12x100	4
10 35	4
8 30	6
12x1.25 /	2
12 /	4
10 /	4
8 /	4
12	8
12	4
10	6
10	8
8	10
8 ()	4
68	4
VH 0216	1
	2
	1
	1
	1
	1
	1
130	1
	1
	1

