



**Инструкция
по монтажу тягово-сцепного
устройства шарового типа 3806 А
для автомобилей
ГАЗ-3110; -31105
“Волга”**

	1997-...
	1300
	75
	14,5



462800,

т. (35363) 7-05-06

ф. (35363) 7-13-20

(495) 785-66-07

www.bosal-autoflex.ru

« - »	(8182) 22-48-15
" 8(8442) 98-74-98	" 8(343) 379-39-89, 373-42-73
" " " 8(343) 26-88-308	" " " 8(3952) 710-194
" " " 8(495) 777-54-59	" " " 8(495) 745-79-11
" " " 8(495) 788-95-97	" " " 8(495) 720-51-03
" " " 8(3532) 57-99-85	" " " 8-905-899-5012
" " " 8(383) 291-59-60	" " " 8(831) 279-53-24
" " " 8(3422) 98-27-20	" " " 8(342) 220-87-87
" " " 8-927-002-90-06	" " " 8(3462) 24-00-44
" " " 8(3842) 21-14-76	" " " 8-902-940-4151
" " " 8(3452) 32-22-12, 41-52-62	" " " 8-961-213-0278
" " " 8-917-347-1700	" " " 8(351) 269-44-75, 900-72-73
" " " 8(3512) 773-76-91	

..... :

..... VIN

.....

.....

41.55-2005.

-
-
-
-
-
-
-
-
-
-
-

()
 « ».
 « » « », 13
 « » « » 18

L=9

1			
2			
3			
4			
5			
6			

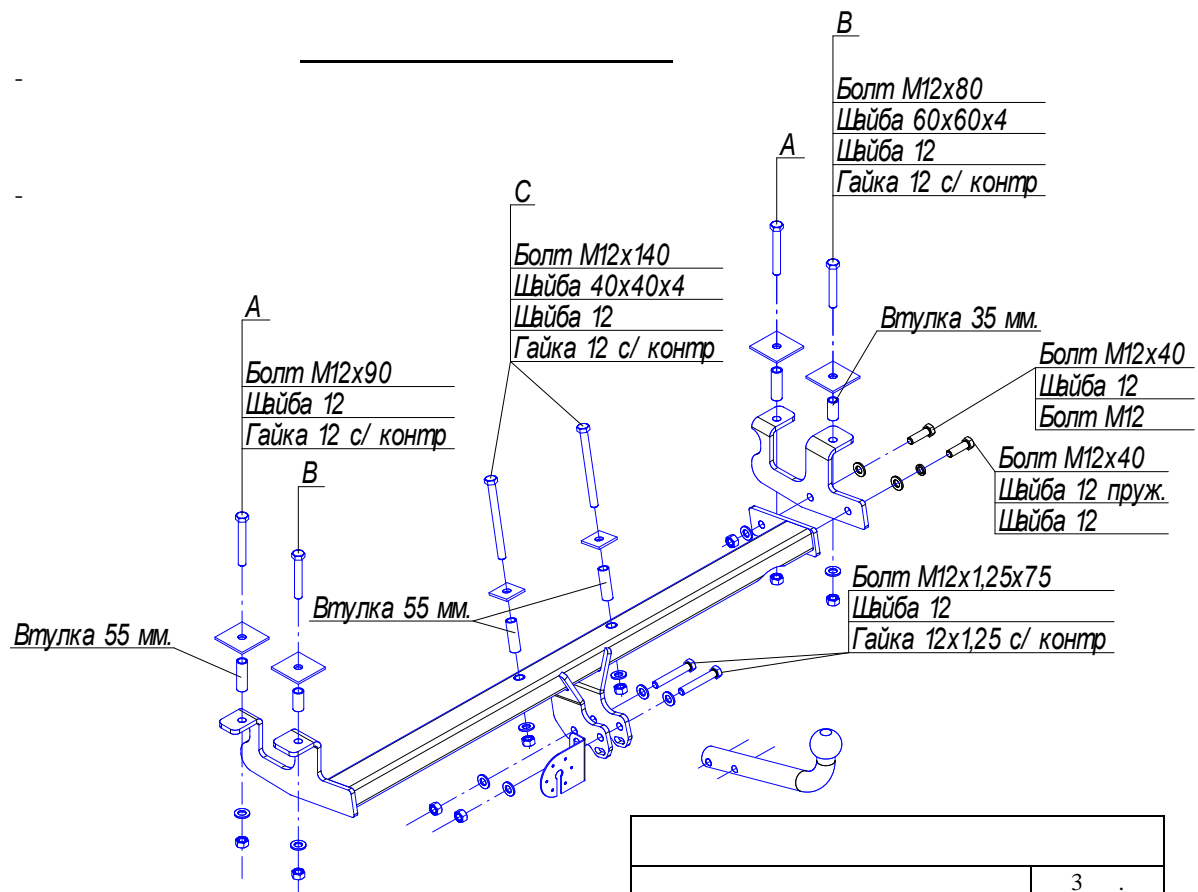

	1
	1
	1
	1

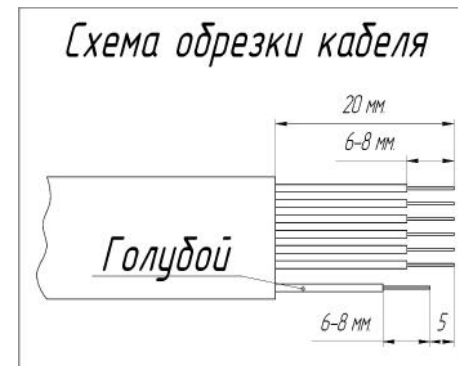

	3
12 1,25 75	2
12 90 1,25	2
12 140	2
12 80	2
12 40	2
12 /	5
12 1,25 /	4
12	13
12	1
12 40 40 4	2
12 60 60 4	4
L = 9	1
L = 35	2
L = 55	4
VH 0165	1
	1
	1
130	1
	1