



**Инструкция
по монтажу тягово-сцепного
устройства шарового типа 3945 А
для автомобилей
Ford Fiesta
Ford Fusion**

	2002/4-2005/9
	1200
	50
	19.5



462800,

« - »
18
: (35363) 7-05-06
/ : (35363) 7-13-20
(495) 799-13-46

www.bosal-autoflex.ru
www.bosal.com

« - »	(8182) 22-48-15
"	" 8(8442) 98-74-98
"	" 8(343) 379-39-89, 373-42-73
"	" 8(343) 26-88-308
"	" 8(3952) 710-194
"	" 8(495) 777-54-59
"	" 8(495) 745-79-11
"	" 8(495) 788-95-97
"	" 8(495) 720-51-03
"	" 8(3532) 57-99-85
"	" 8-905-899-5012
"	" 8(383) 291-59-60
"	" 8(831) 279-53-24
"	" 8(3422) 98-27-20
"	" 8(342) 220-87-87
"	" 8-927-002-90-06
"	" 8(3462) 24-00-44
"	" 8(3842) 21-14-76
"	" 8-902-940-4151
"	" 8(3452) 32-22-12, 41-52-62
"	" 8-961-213-0278
"	" 8-917-347-1700
"	" 8(351) 269-44-75, 900-72-73
"	" 8(3512) 773-76-91

Ford Fiesta:

«а». (2.,3)

(1)

«b»

Ford Fusion:

(2,3)

(1)

« »

« » «b» (

()

« » ()

).

(4)

«y» (

1			
2			
3			
4			
5			
6			
7			

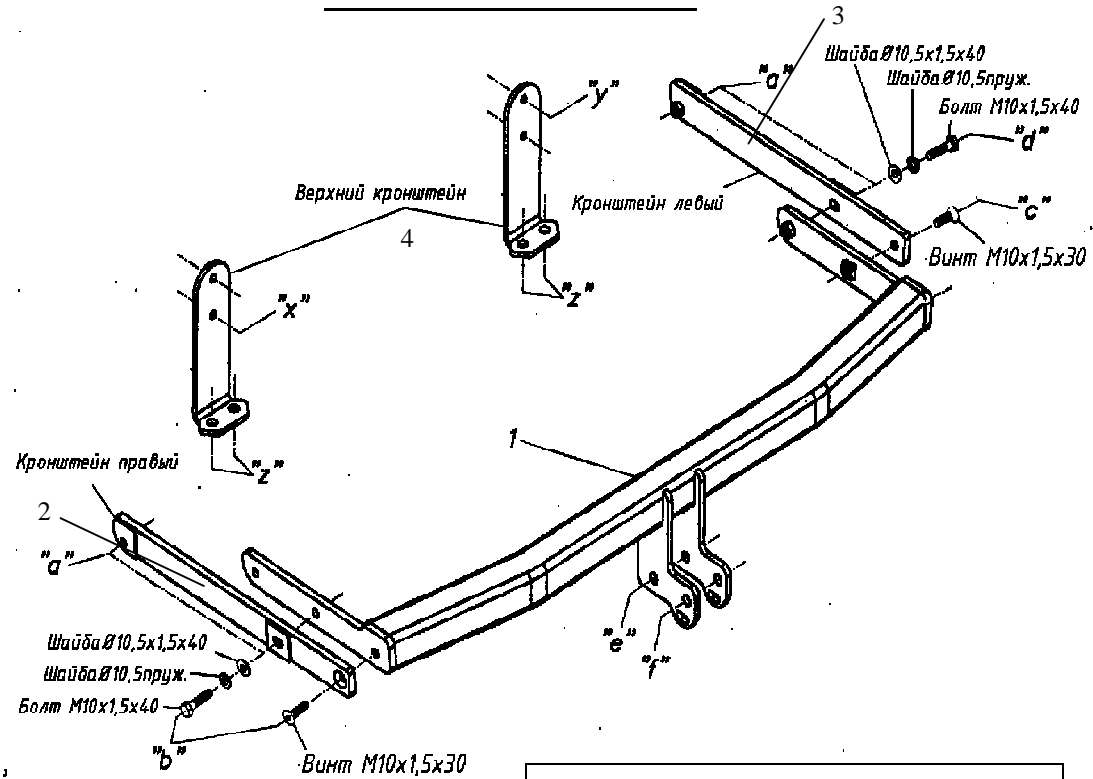

	1
	1
	1
	1
	1
	1

	3
10 30	2
10 40	4
12 1,25 90	2
12 1,25 /	2
10	4
10	4
12	3
4,8 16	6
	2
	2
VH 0187	1
	1
	1
	1
190	1
	1
	1

Схема обрезки кабеля

