

Fitting instructions

Make: Toyota

RAV 4: 2006->

Type: 4754

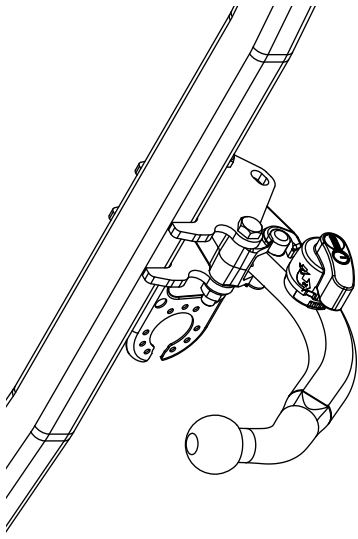

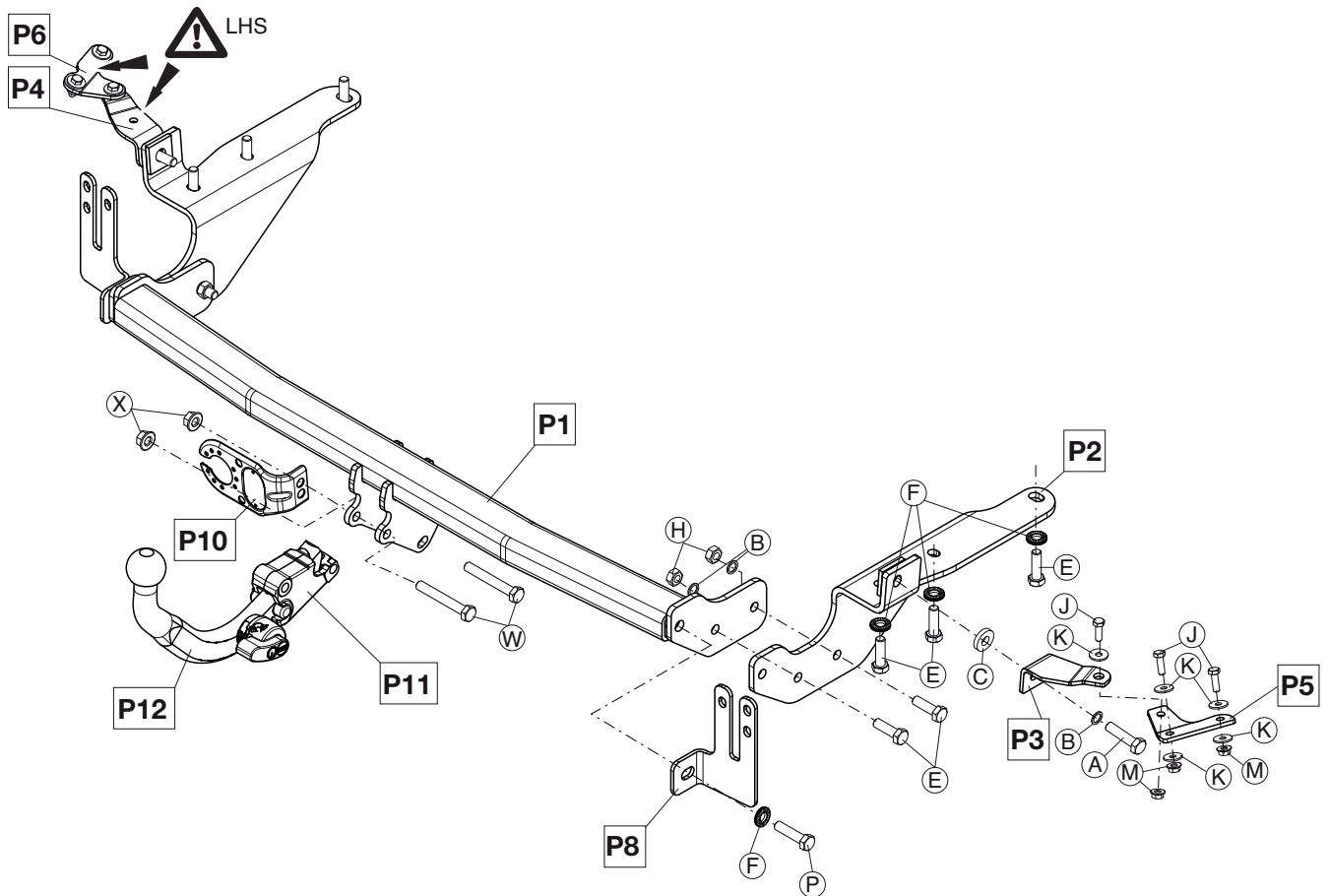

© 475470MN/08-06-2007/1



Dispositivo di traino tipo: 4754
 Per autoveicoli: Toyota RAV 4; 2006->
 Tipo funzionale: ACA30*-AW**KW
 ALA30*-AW**YW
 Classe e tipo di attacco: A50-X
 Omologazione: e11 00-6056
 Valore D: 10,4 kN
 Carico Verticale max. S: 90 kg
 Larghezza rimorchiabile per Caravan e T.A.T.S.: 2,45m vedere CARTA di CIRCOLAZIONE VEICOLO (motrice) + 70 cm = ..arrotondare ai 5 cm superiore (vedi D.M.28/05/85)
 Massa rimorchiabile: vedi carta di circolazione dell' autoveicolo

Per verificare l' idoneità del dispositivo di traino omologato a norma CEE 94/20, all' installazione sulla vettura su cui si intende procedere al montaggio, compilare la seguente formula (se necessario declassare la massa rimorchiabile):

$$D = \frac{T \times C}{T + C} \times 0,00981 \leq 10,4 \text{ kN}$$

dove: T= Massa Complessiva Max. della motrice (in kg)
 C= Massa Rimorchiabile Max. della motrice (in kg)









DA COMPILARE PER IL COLLAUDO



DICHIARAZIONE DI CORRETTO MONTAGGIO: la sottoscritta Ditta dichiara di aver montato in maniera corretta ed in conformità/ alle prescrizioni sia del costruttore del veicolo che del costruttore del dispositivo stesso il seguente dispositivo di attacco meccanico:

tipo:.....
 Il dispositivo di attacco sopra indicato è stato installato su autoveicolo
 modello:.....
 targa:.....
 Data:.....

TIMBRO e FIRMA

Si dichiara inoltre di aver informato l'utente del veicolo sull'USO e MANUTENZIONE del dispositivo stesso.

	(2x) M12x1,25x50	A
	(6x) M12	B
	(2x) ø30x13 L=6	C
	(10x) M12x1,25x40	E
	(8x) M12	F
	(4x) M12x1,25	H
	(6x) M8x25	J
	(10x) ø24x8,4x2	K
	(6x) M8	M

	(2x) M12x50	P
	(2x) M12x85	W
	(2x) M12 Self-locking	X

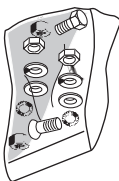
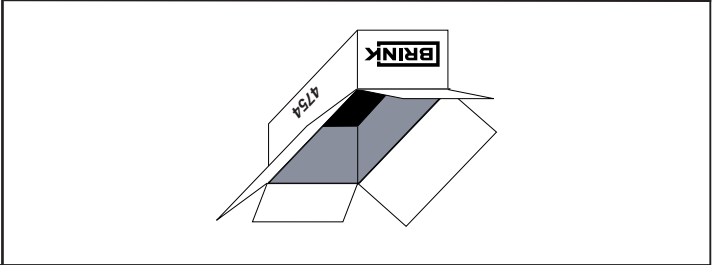
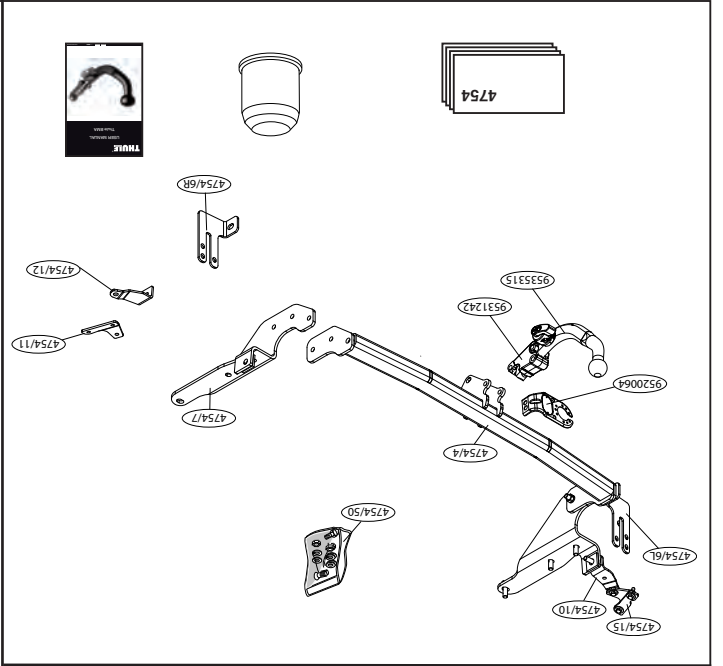

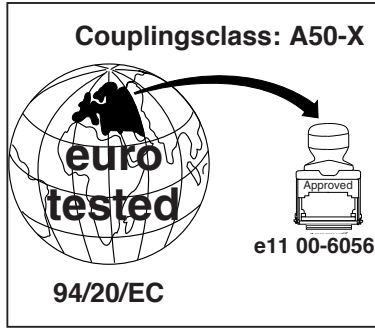
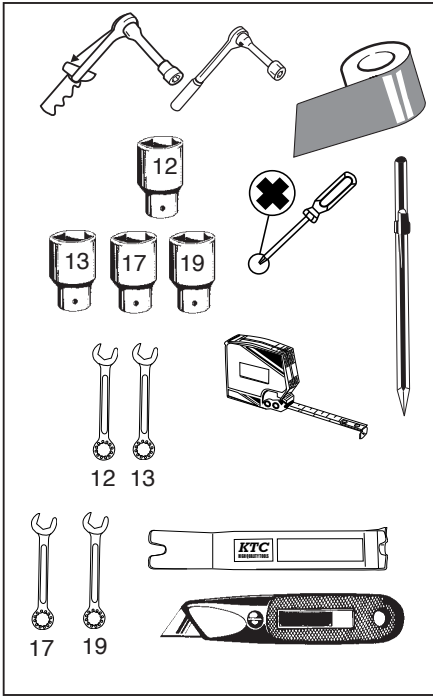

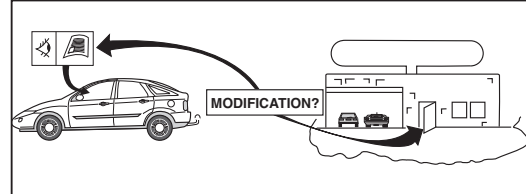
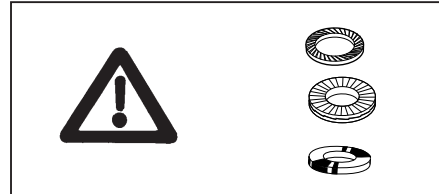
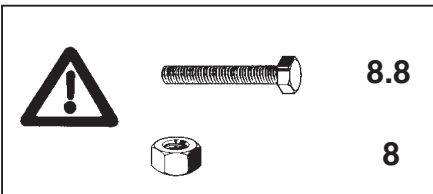
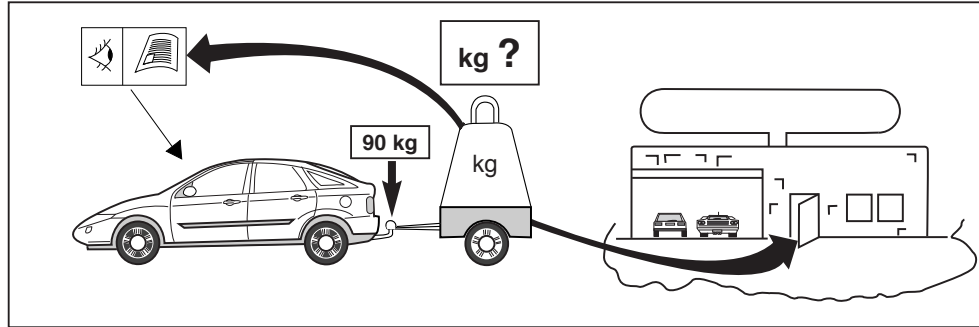

D-Value : 10,4 kN

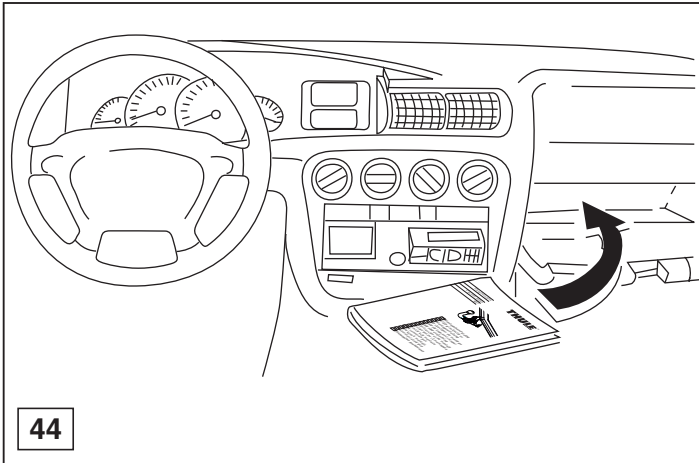

© 475470MN/08-06-2007/3



* Should this installation process entail the cutting of the bumper – conformation MUST be obtained by the installation engineer of the customer's acceptance prior to completion. Brink International do not accept responsibility for any matters arising as a result of this miscommunication.

* All measurements are in mm!

NOTE:

* Die für das Fahrzeug zugelassene Anhängelast ist den Fahrzeug Unterlagen zu entnehmen. Bei Änderungen des Fahrzeuggewichtes muß die höchstzulässige Anhängelast gegebenenfalls aus dem D-Wert nachgerechnet werden.

* Auskunft hierüber kann ihr Fachhändler oder der TÜV geben.

* Elektrische Anlage gemäß StVZO anbringen.

HINWEISE:

Torque settings for nuts and bolts (8.8)

1000km	+	0km	
75Nm	W	75Nm	P
25Nm	M	40Nm	Ac + AD
	13		12
	19		19

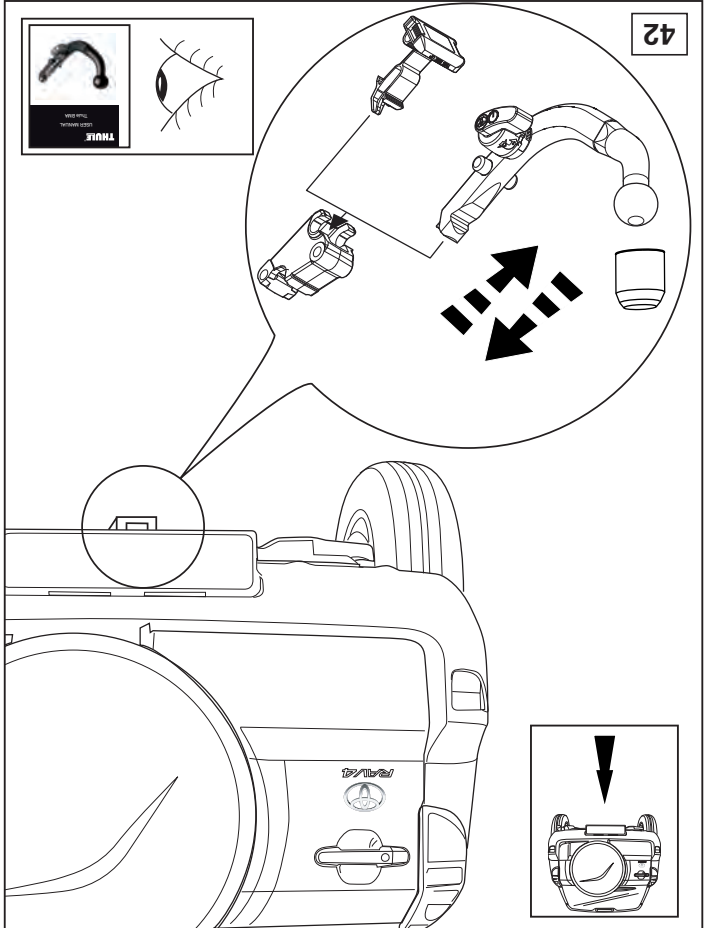
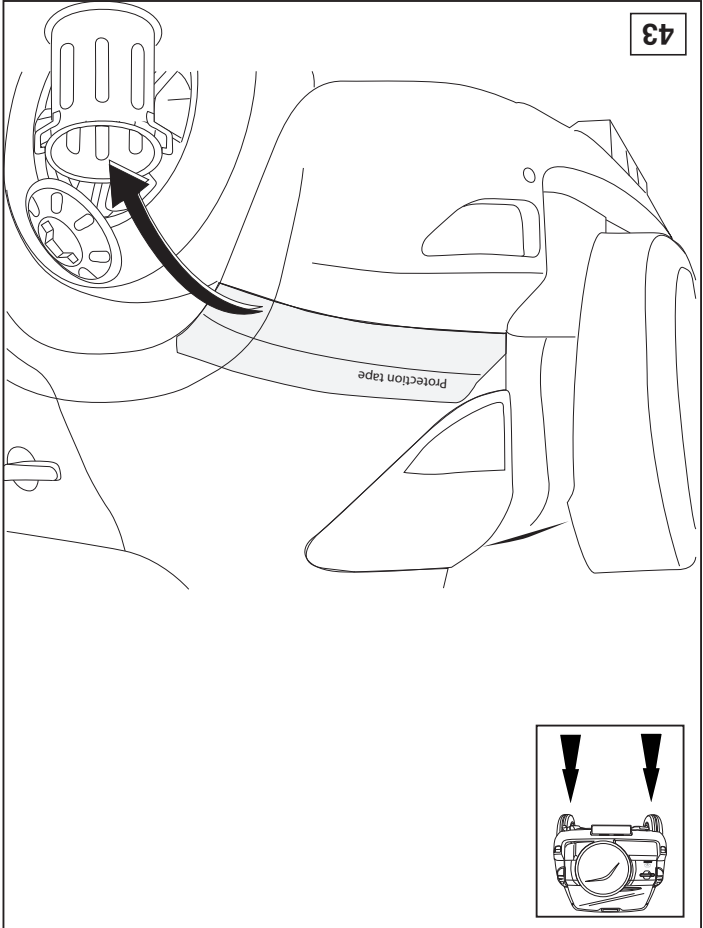

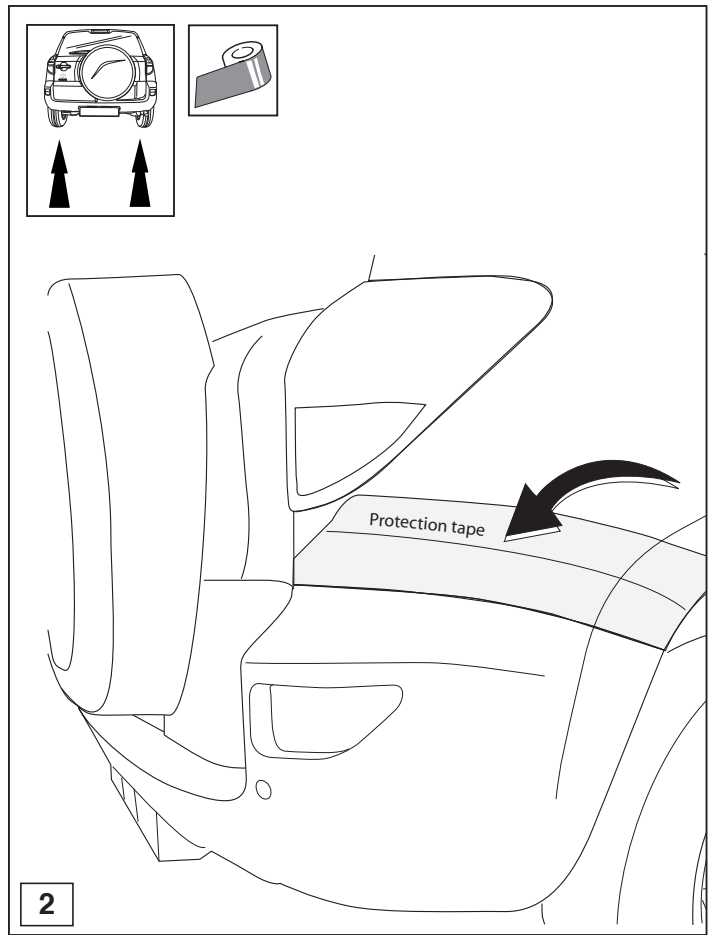
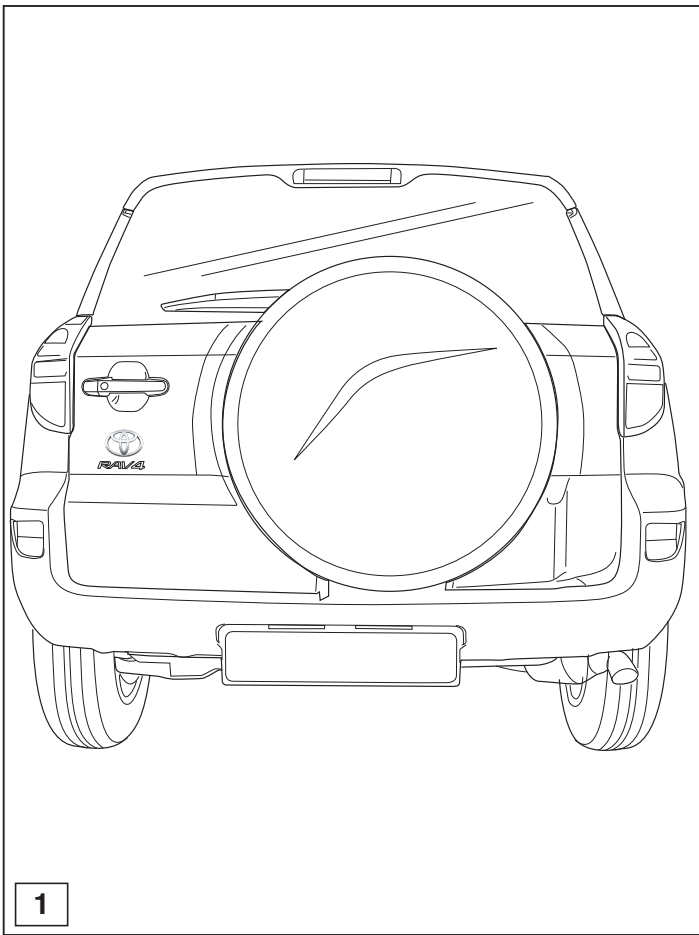

© 475470MN/08-06-2007/5

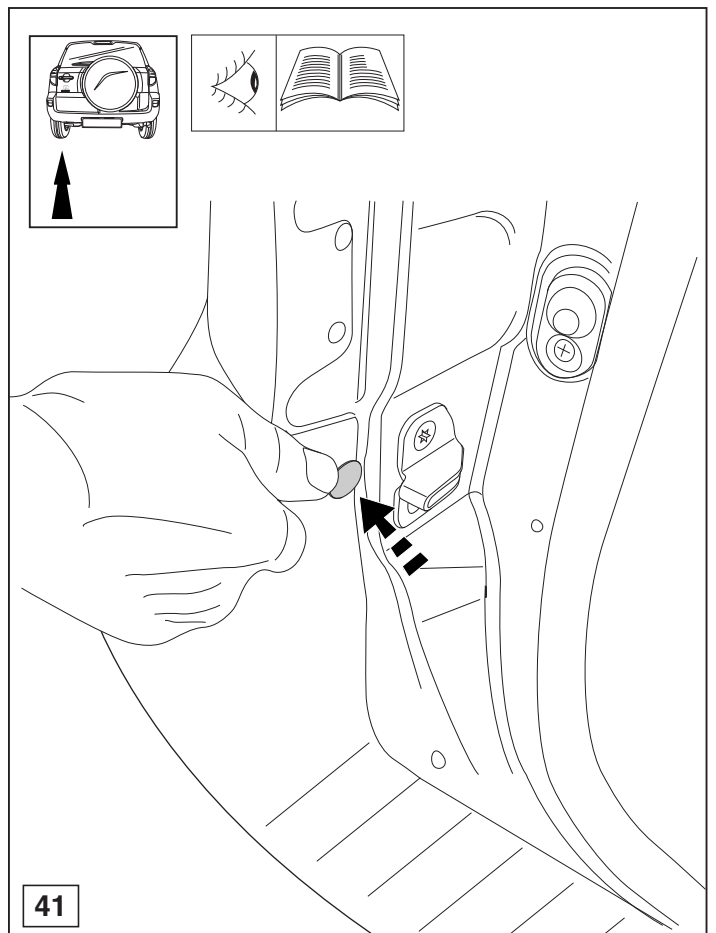
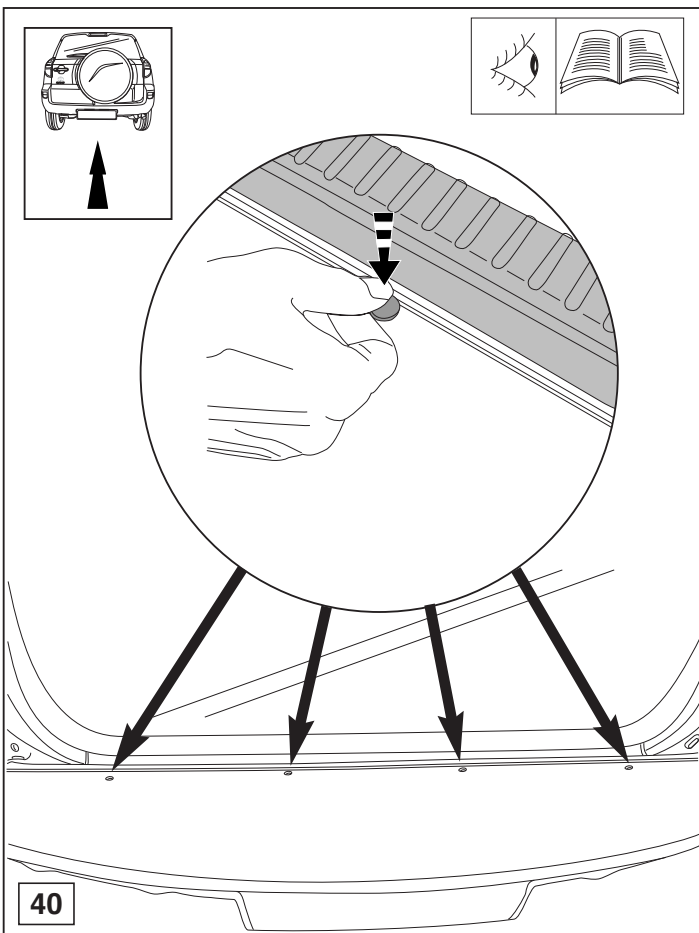

© 475470MN/08-06-2007/26

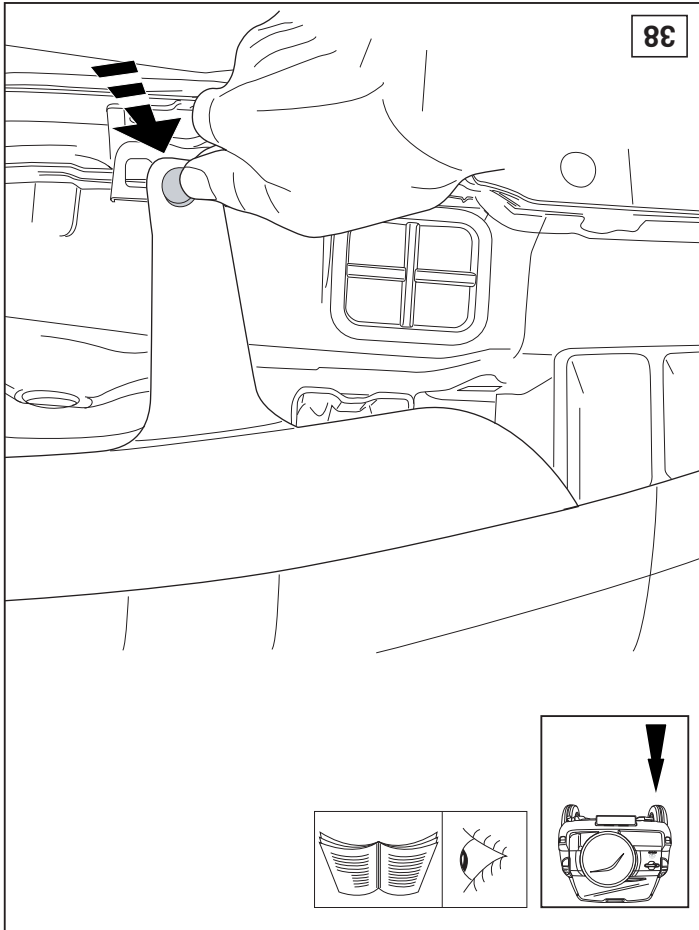
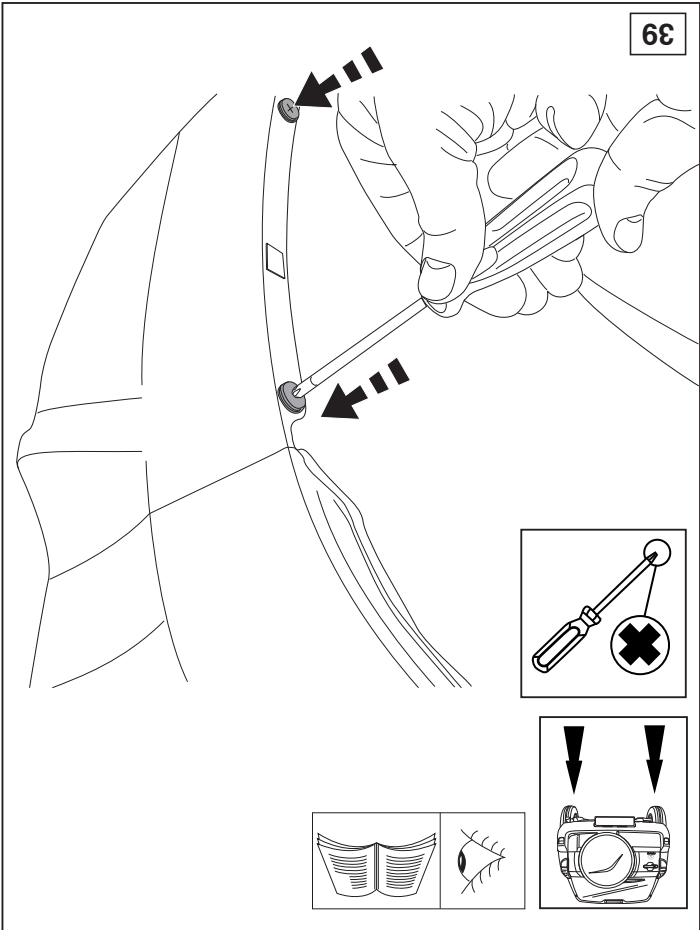
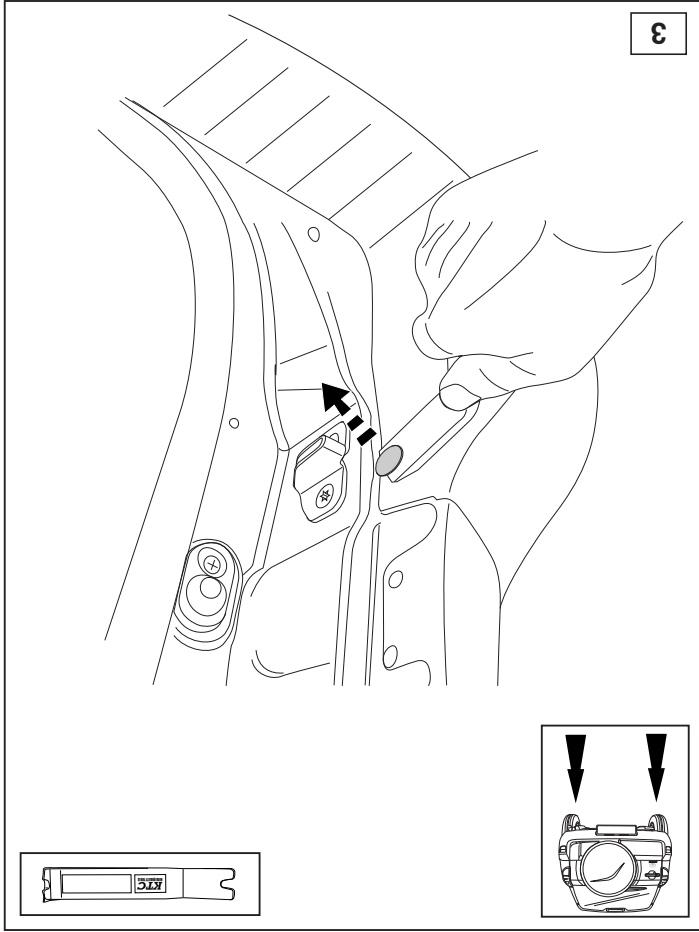
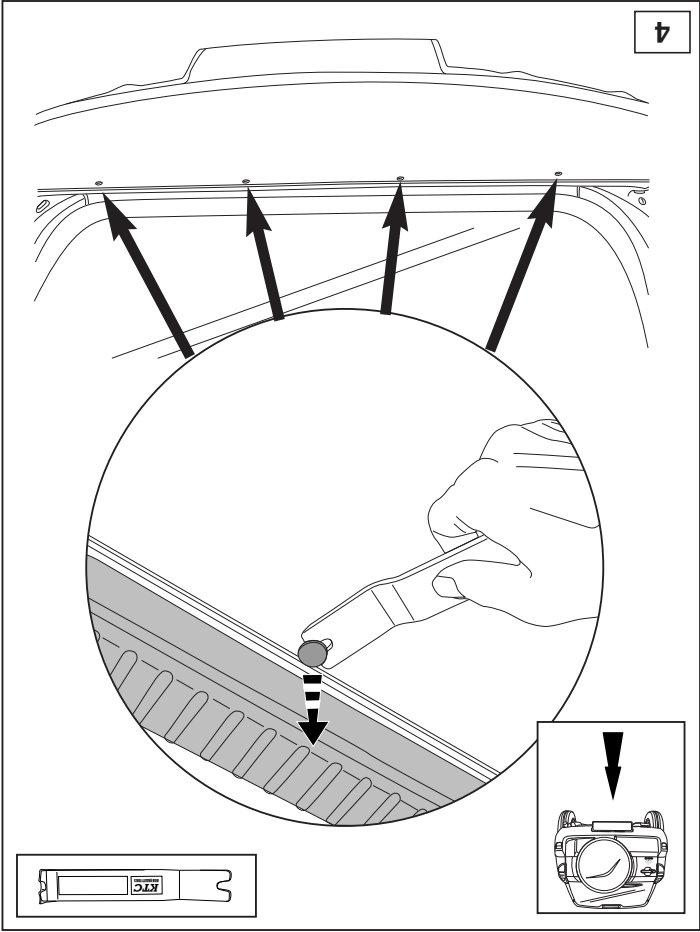

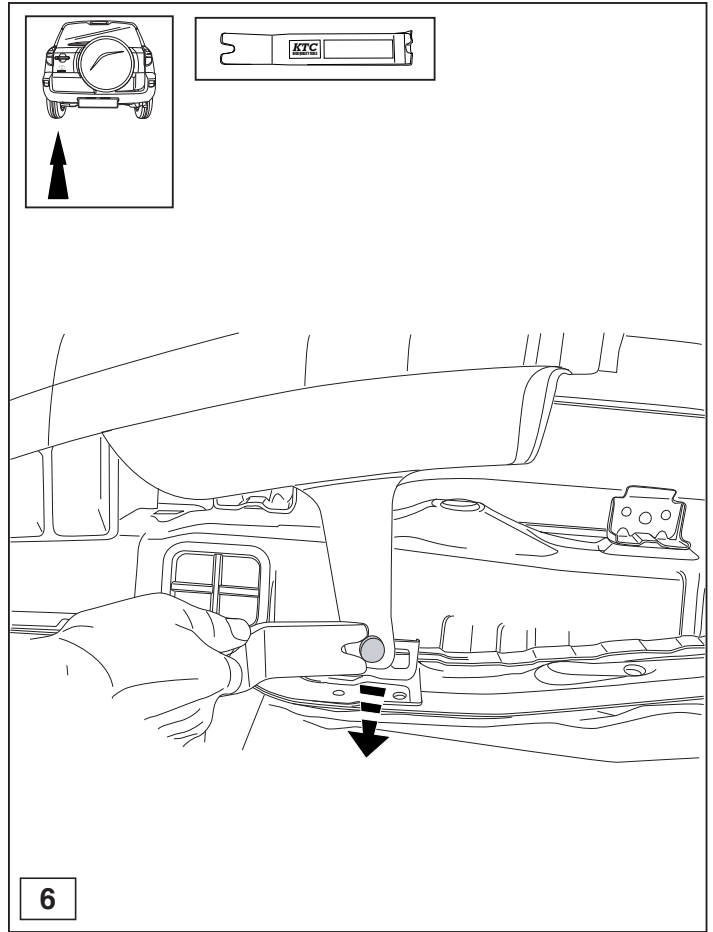
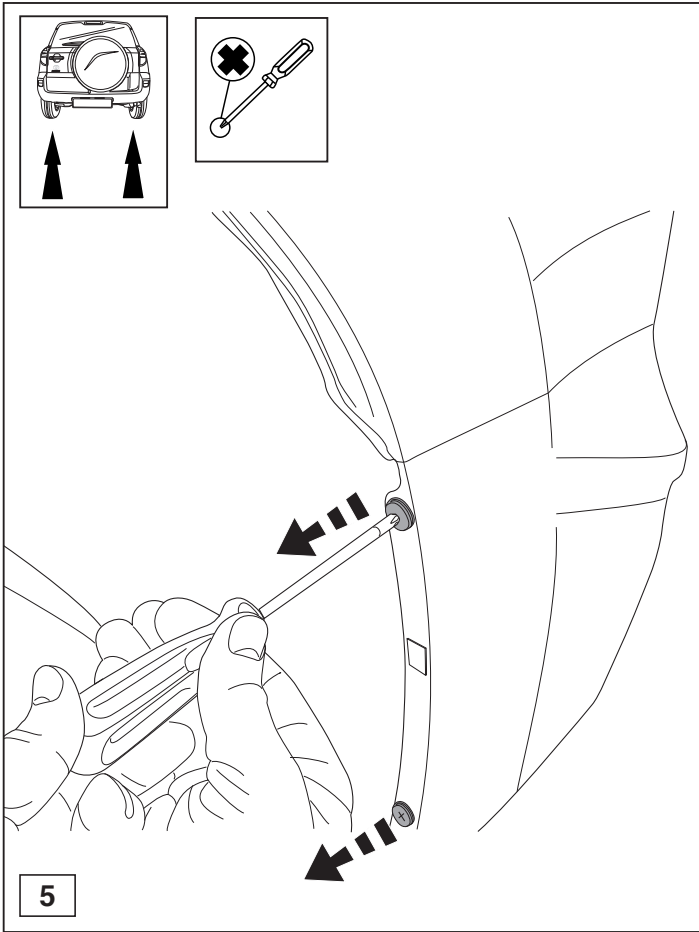

© 475470MN/08-06-2007/7

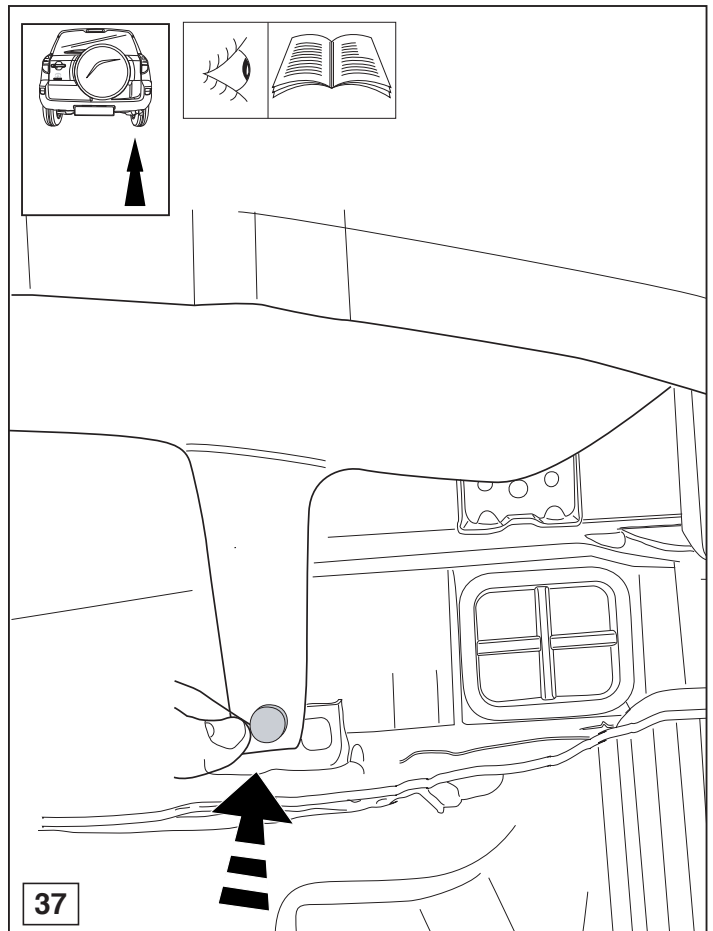
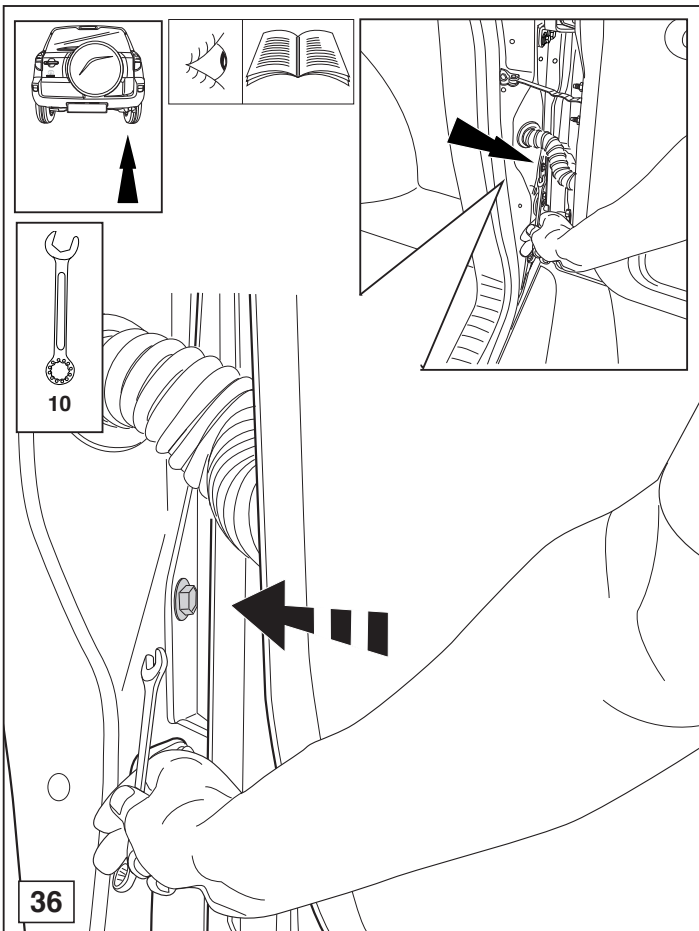

© 475470MN/08-06-2007/24

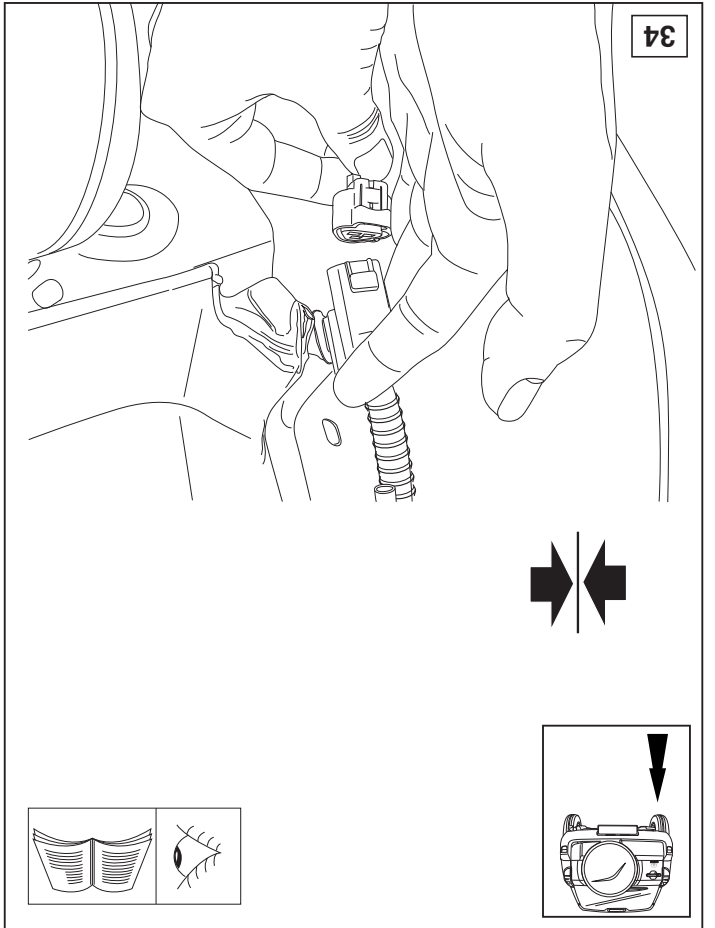
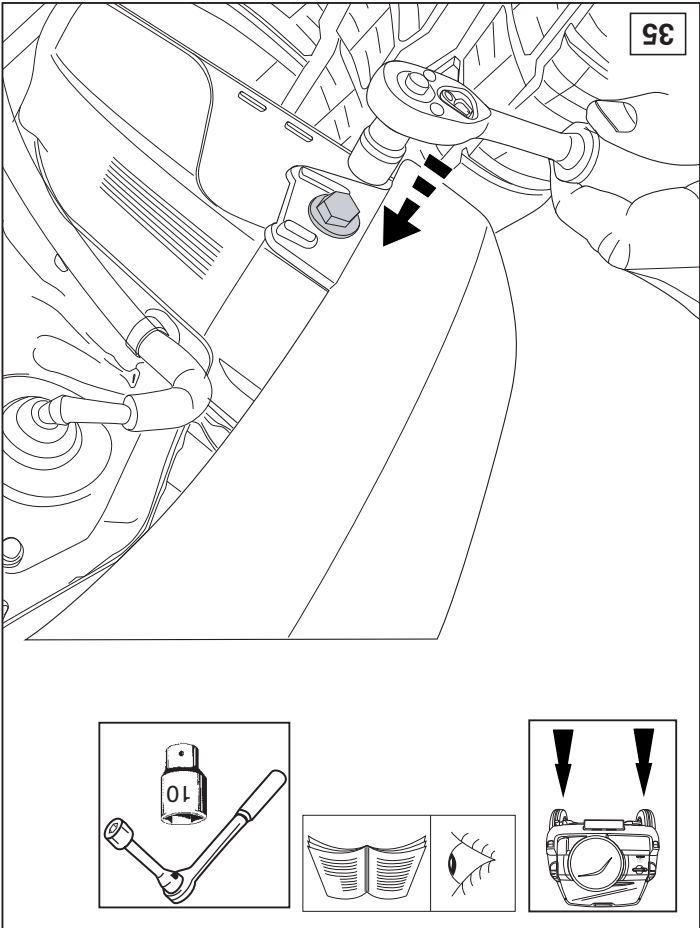
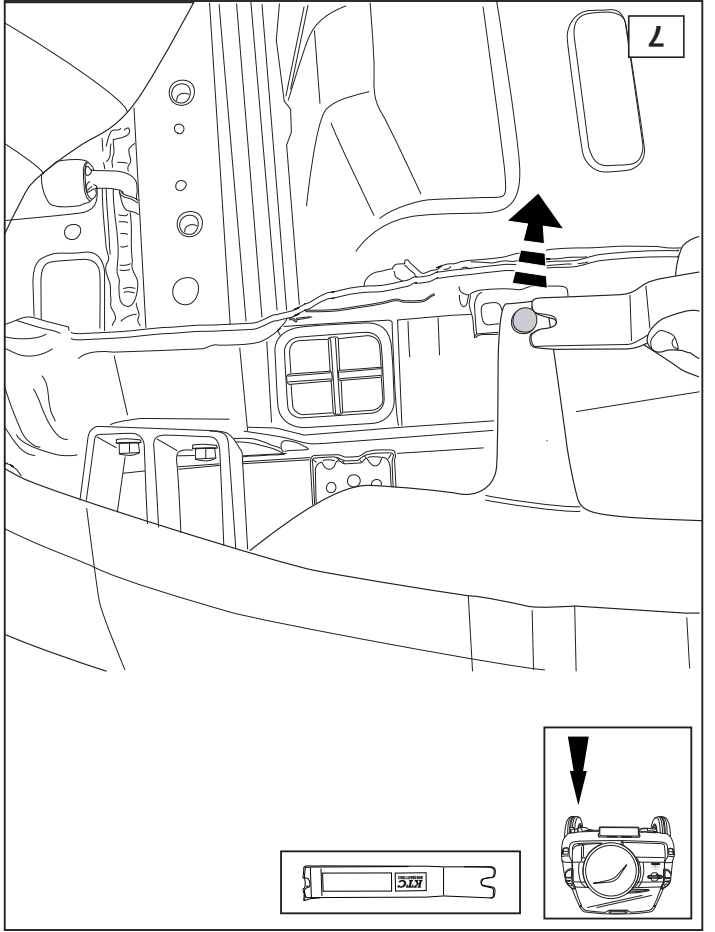
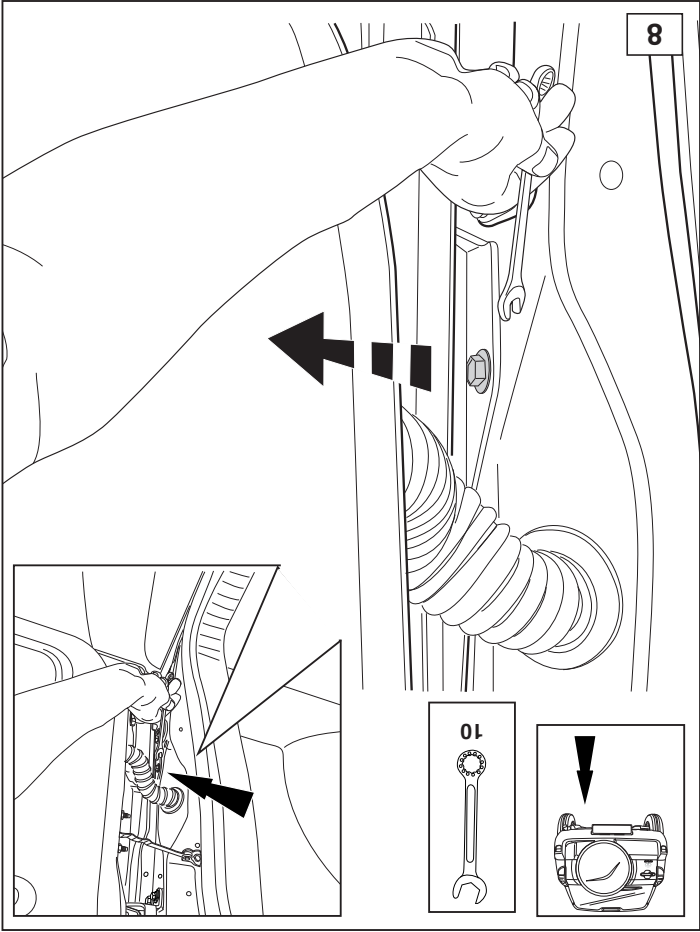

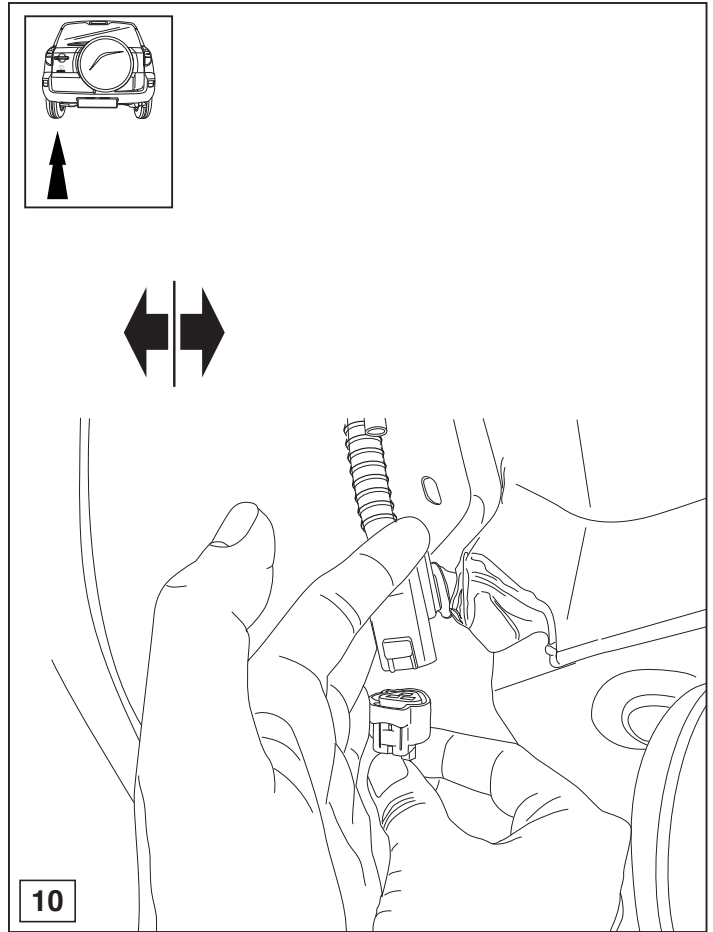
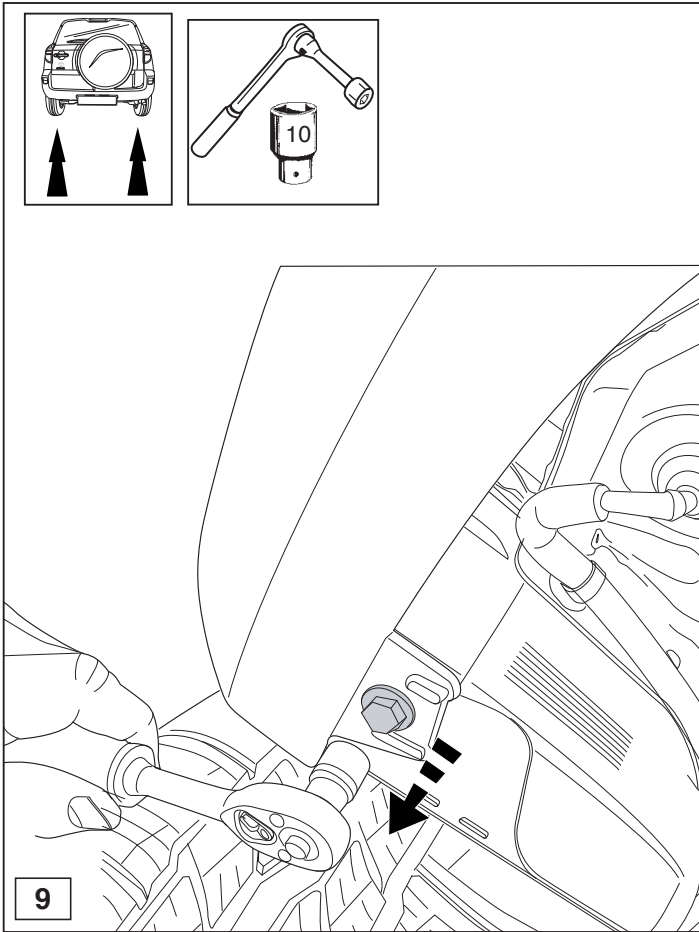

© 475470MN/08-06-2007/9

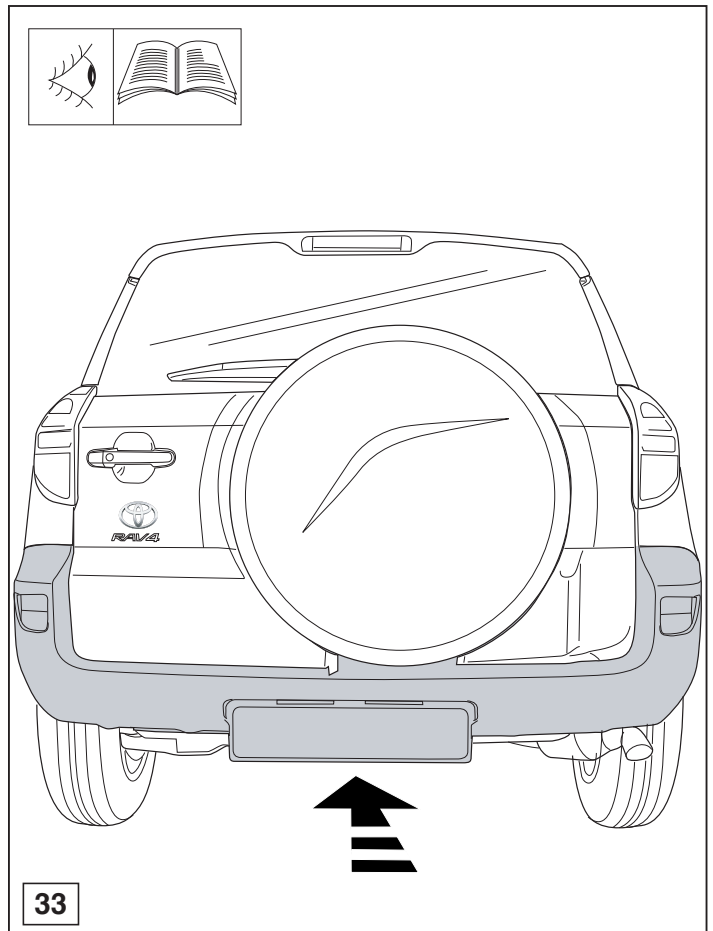
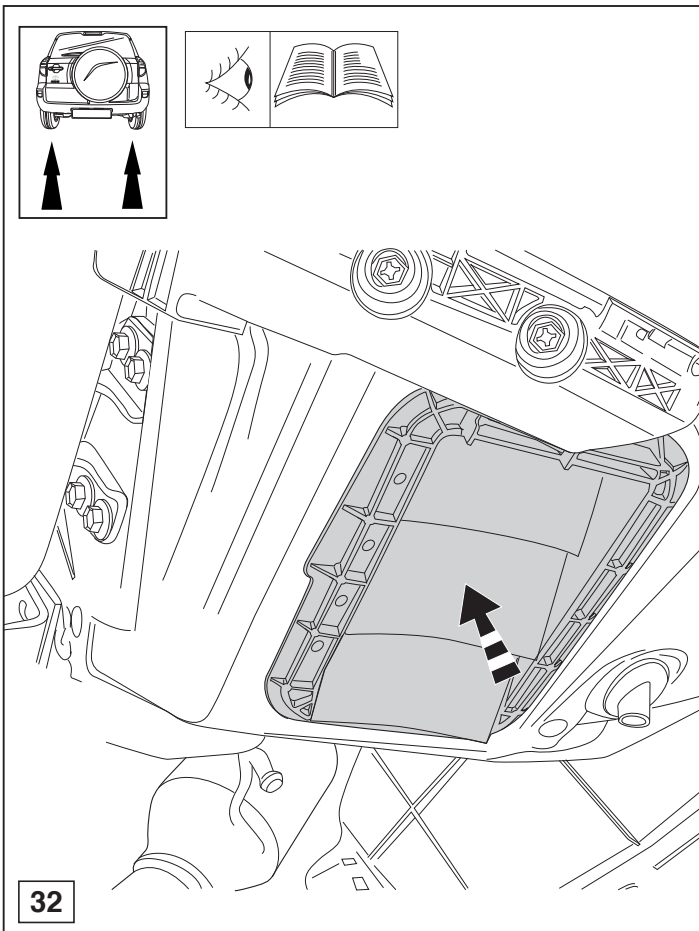

© 475470MN/08-06-2007/22

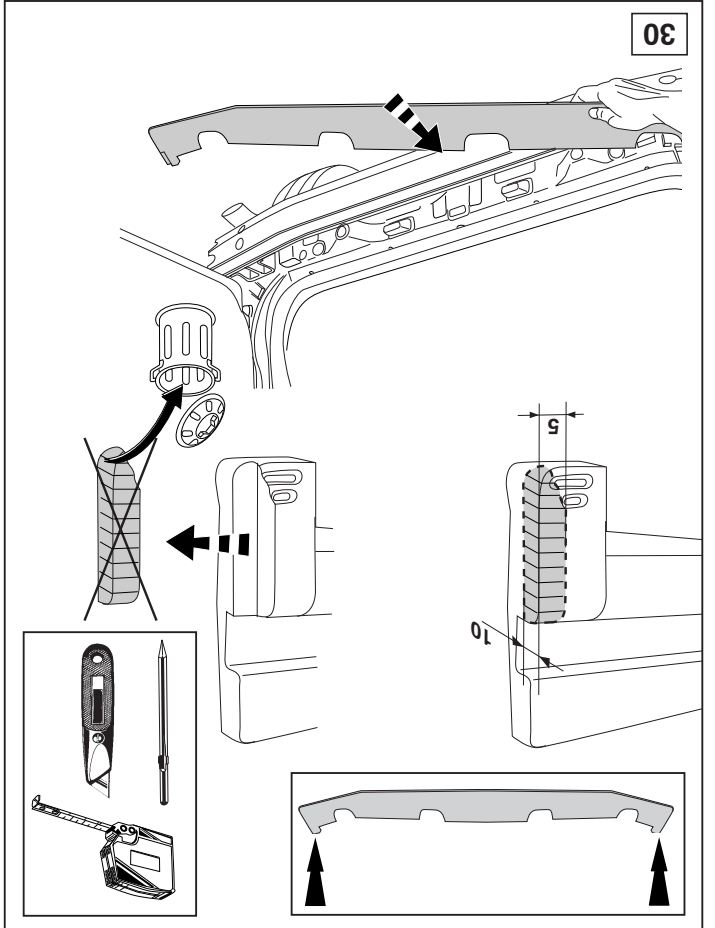
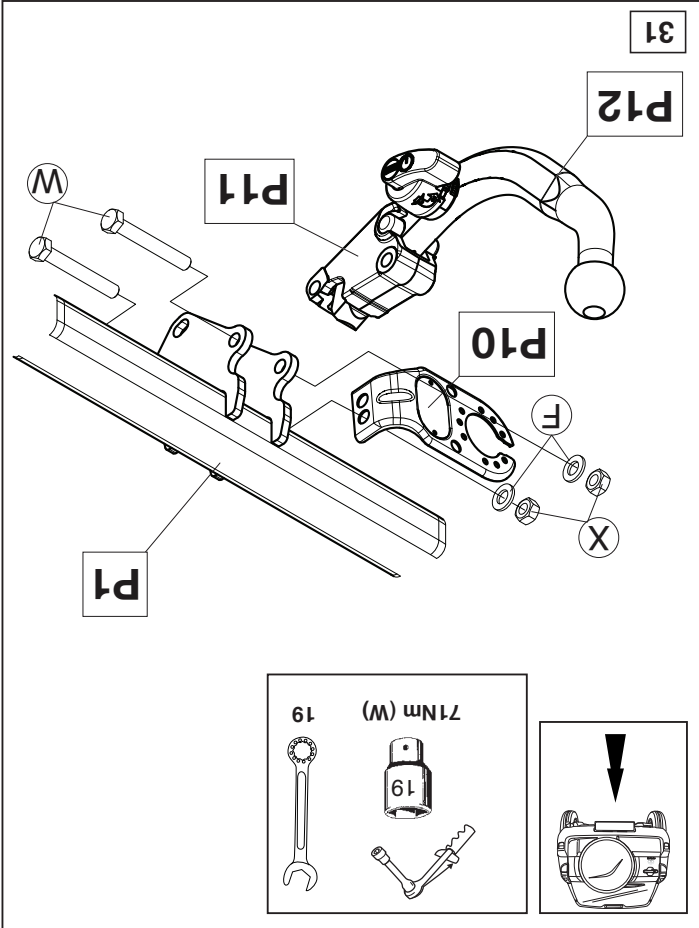
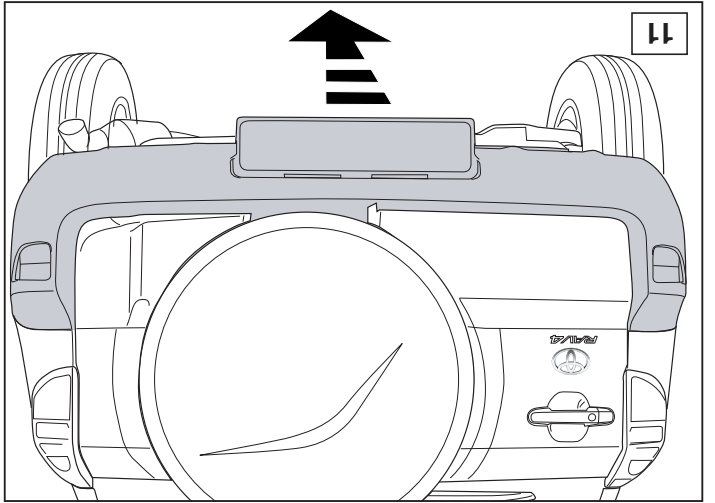
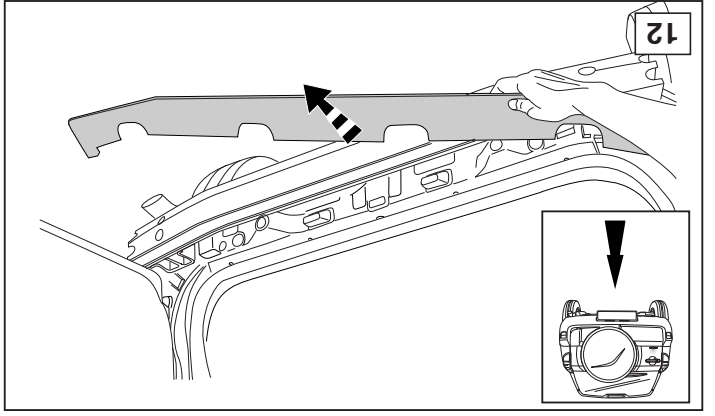
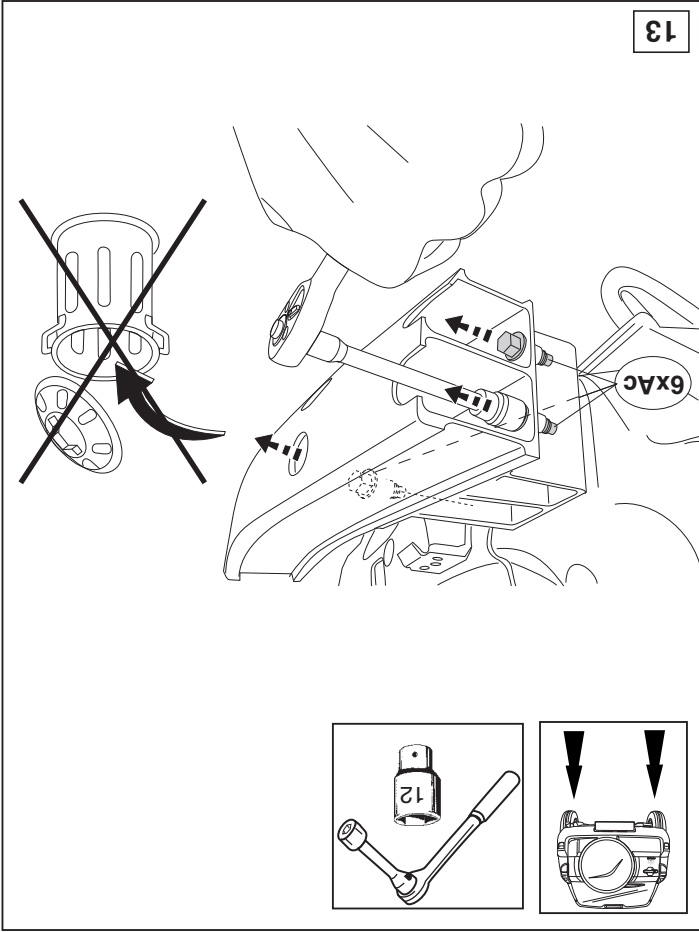

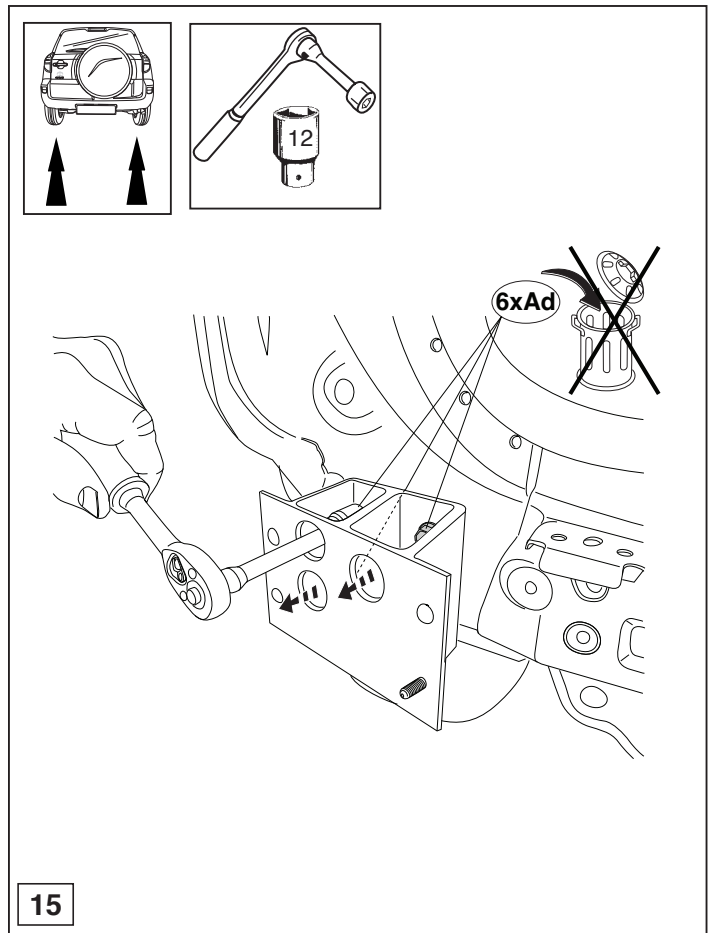
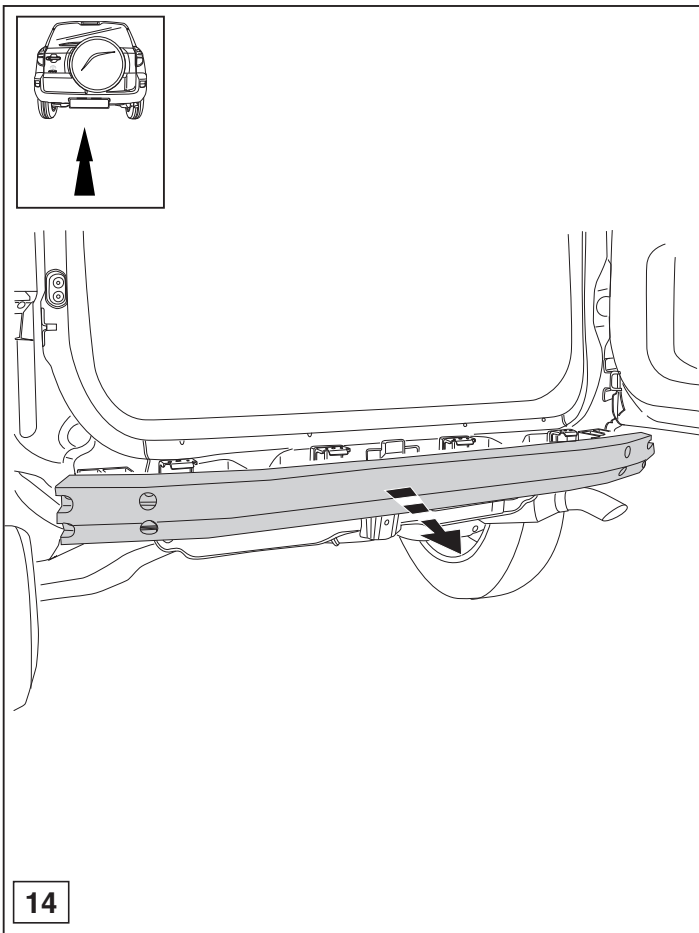

© 475470MN/08-06-2007/11

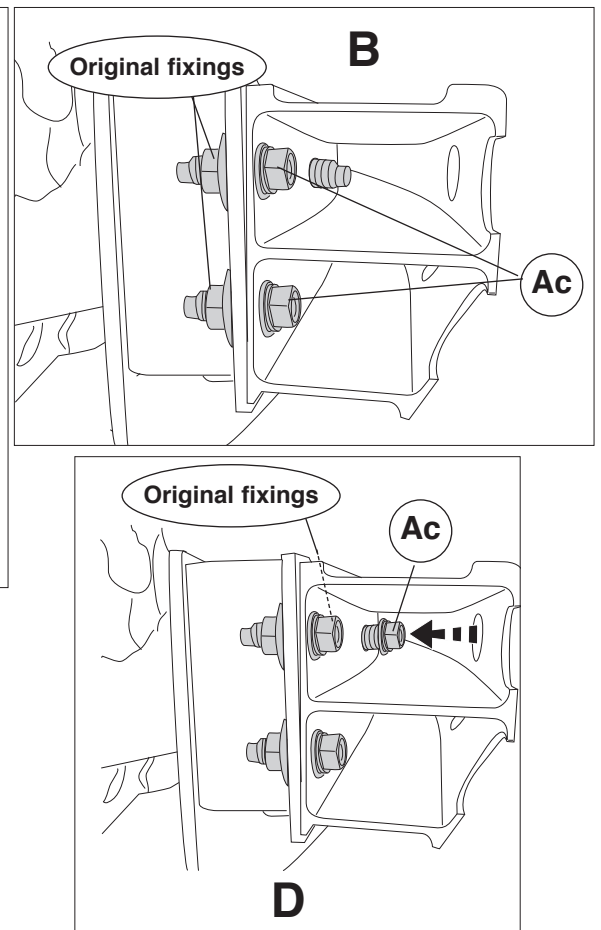
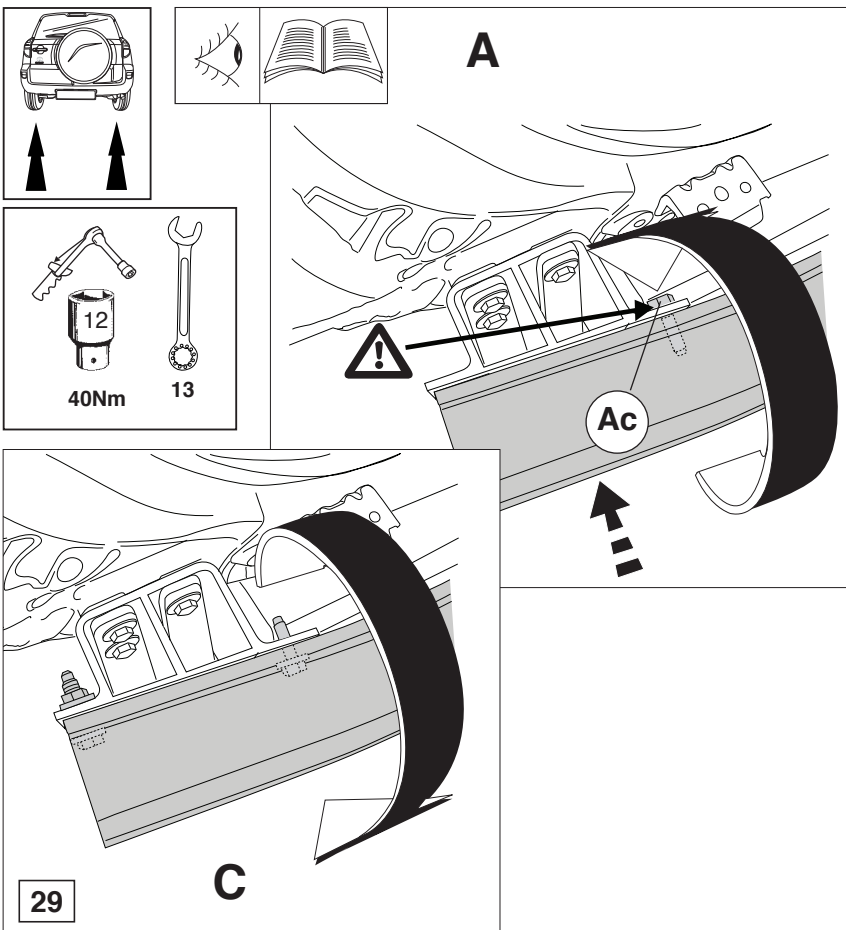

© 475470MN/08-06-2007/20

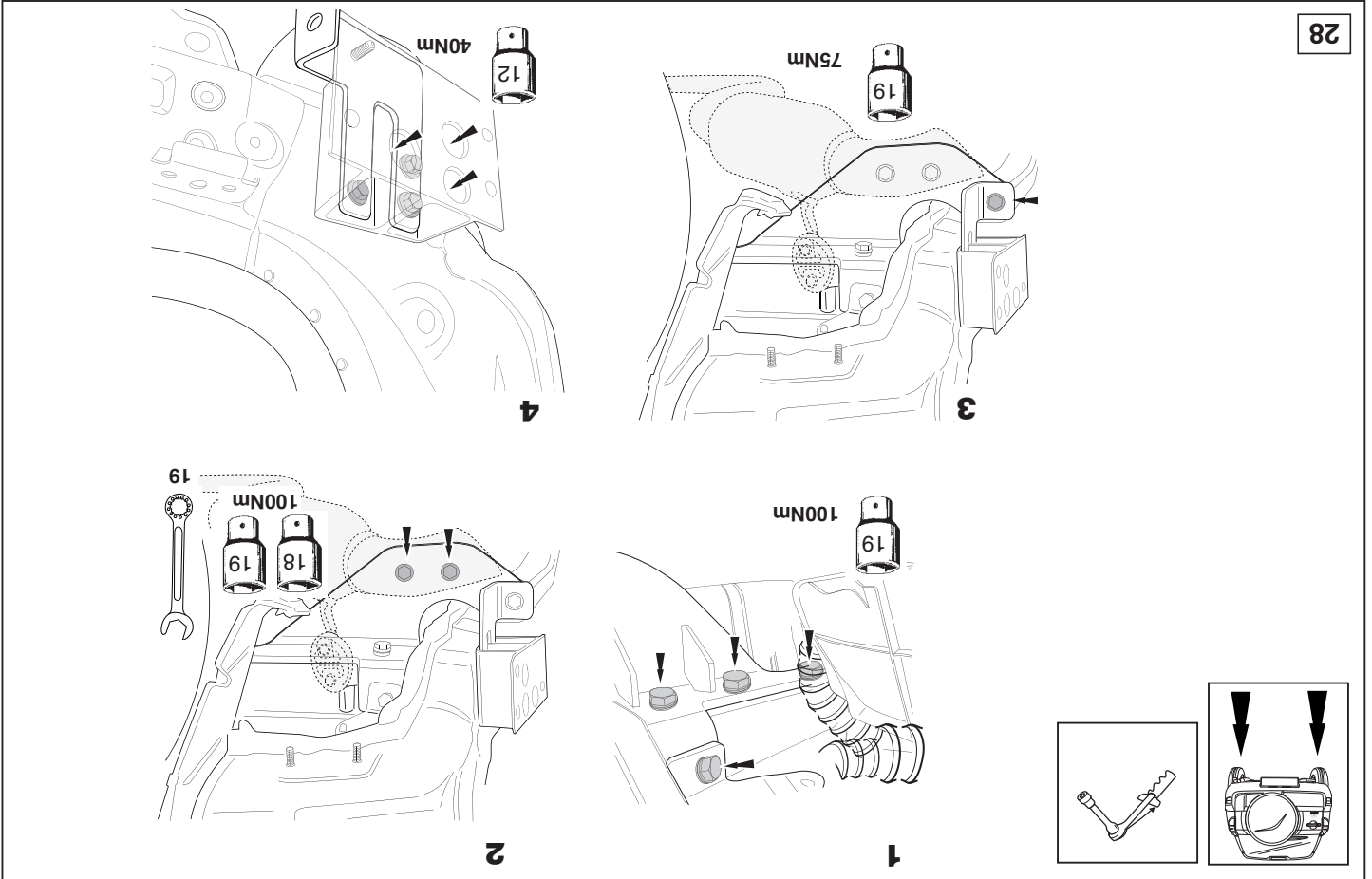
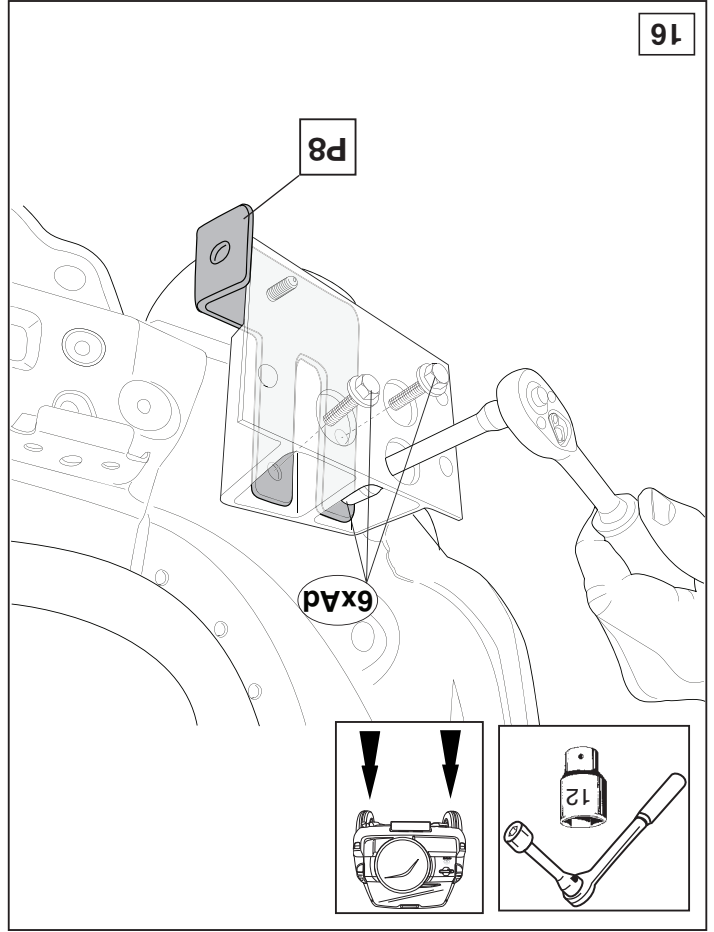
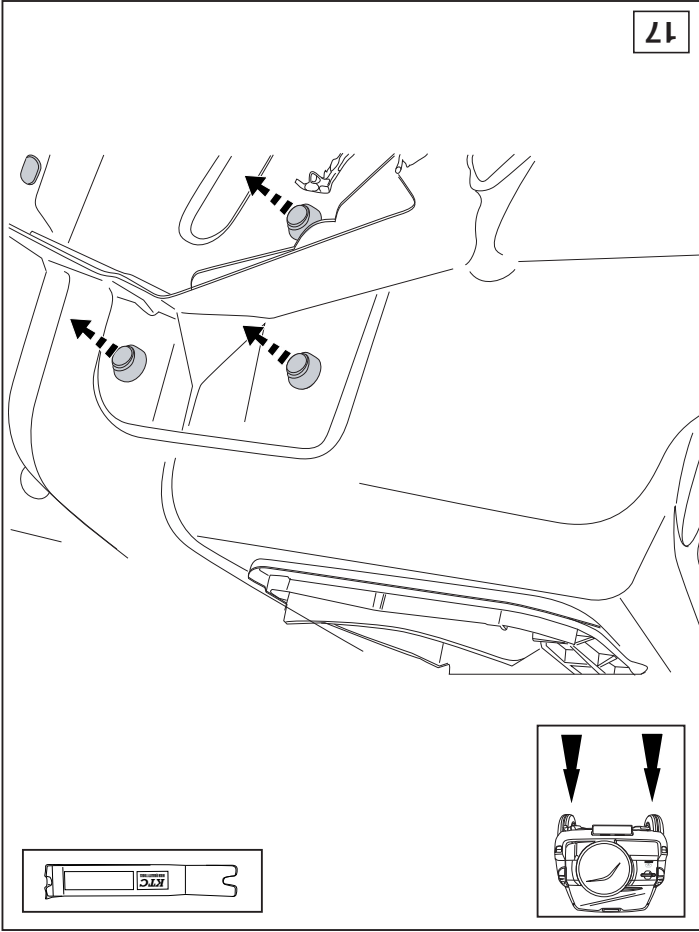

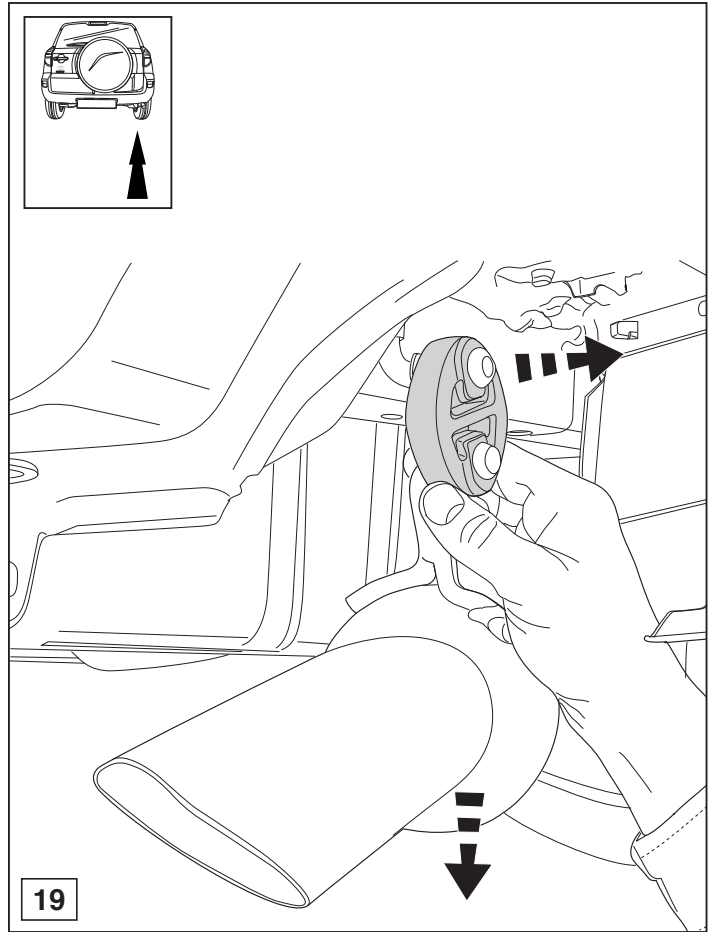
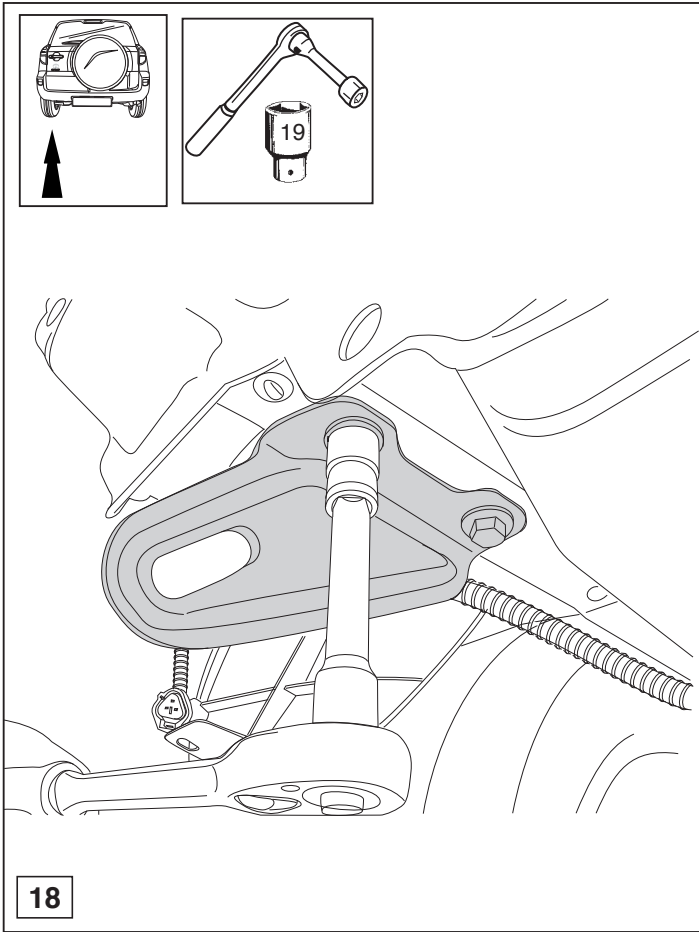

© 475470MN/08-06-2007/13

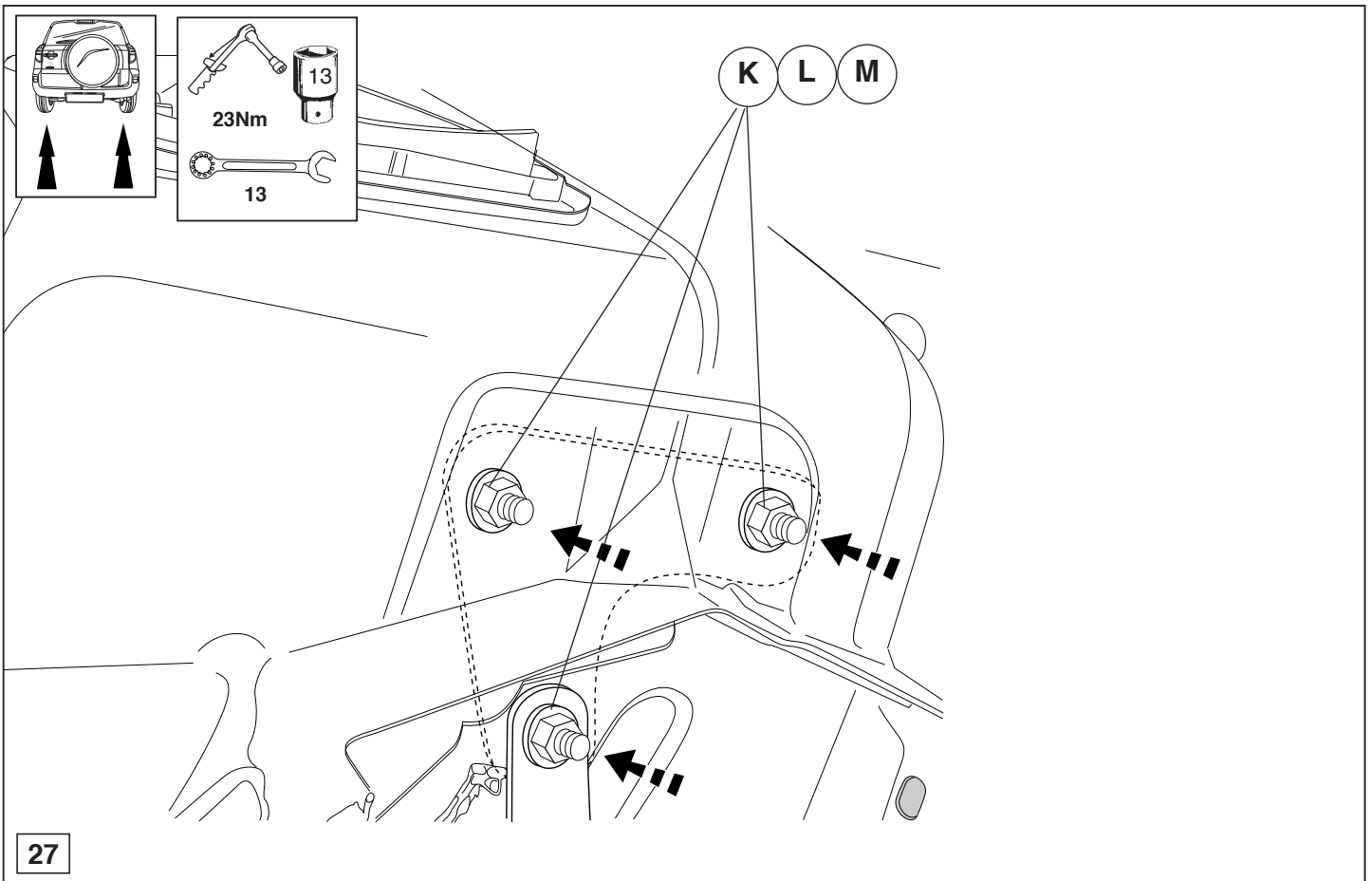

© 475470MN/08-06-2007/18

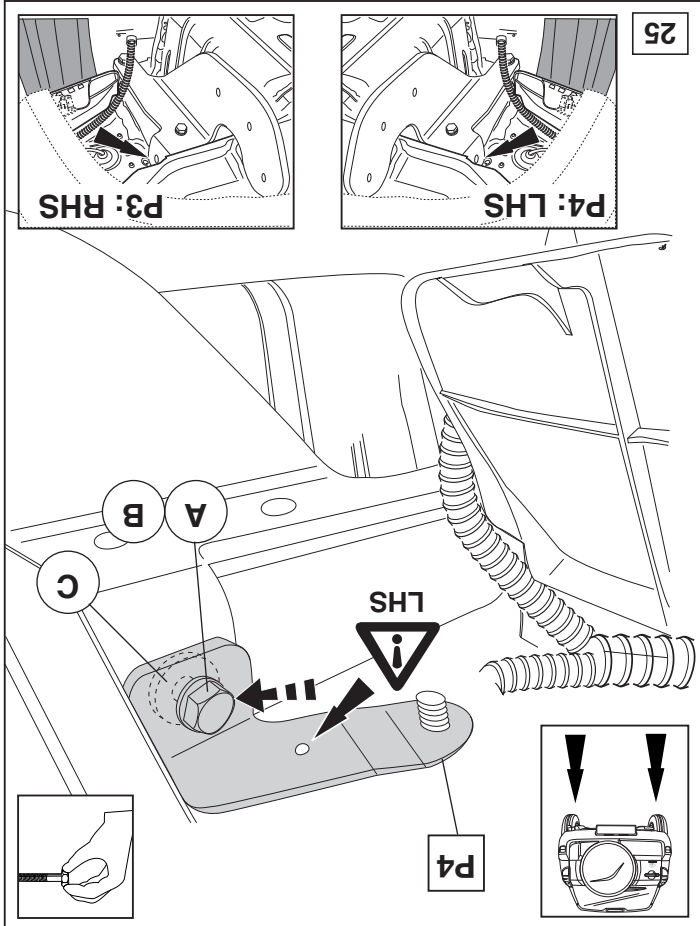
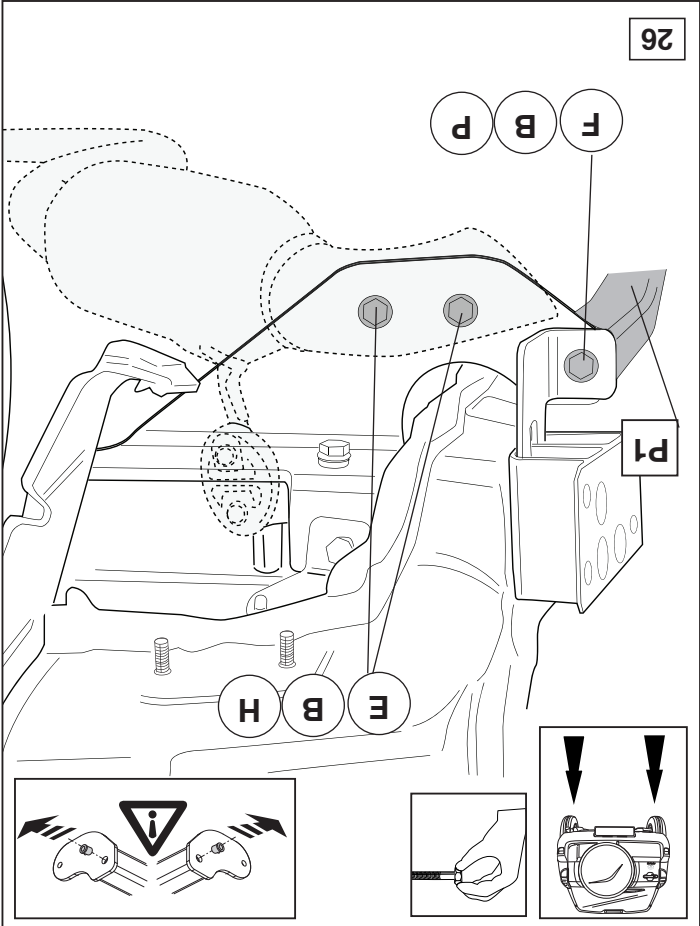
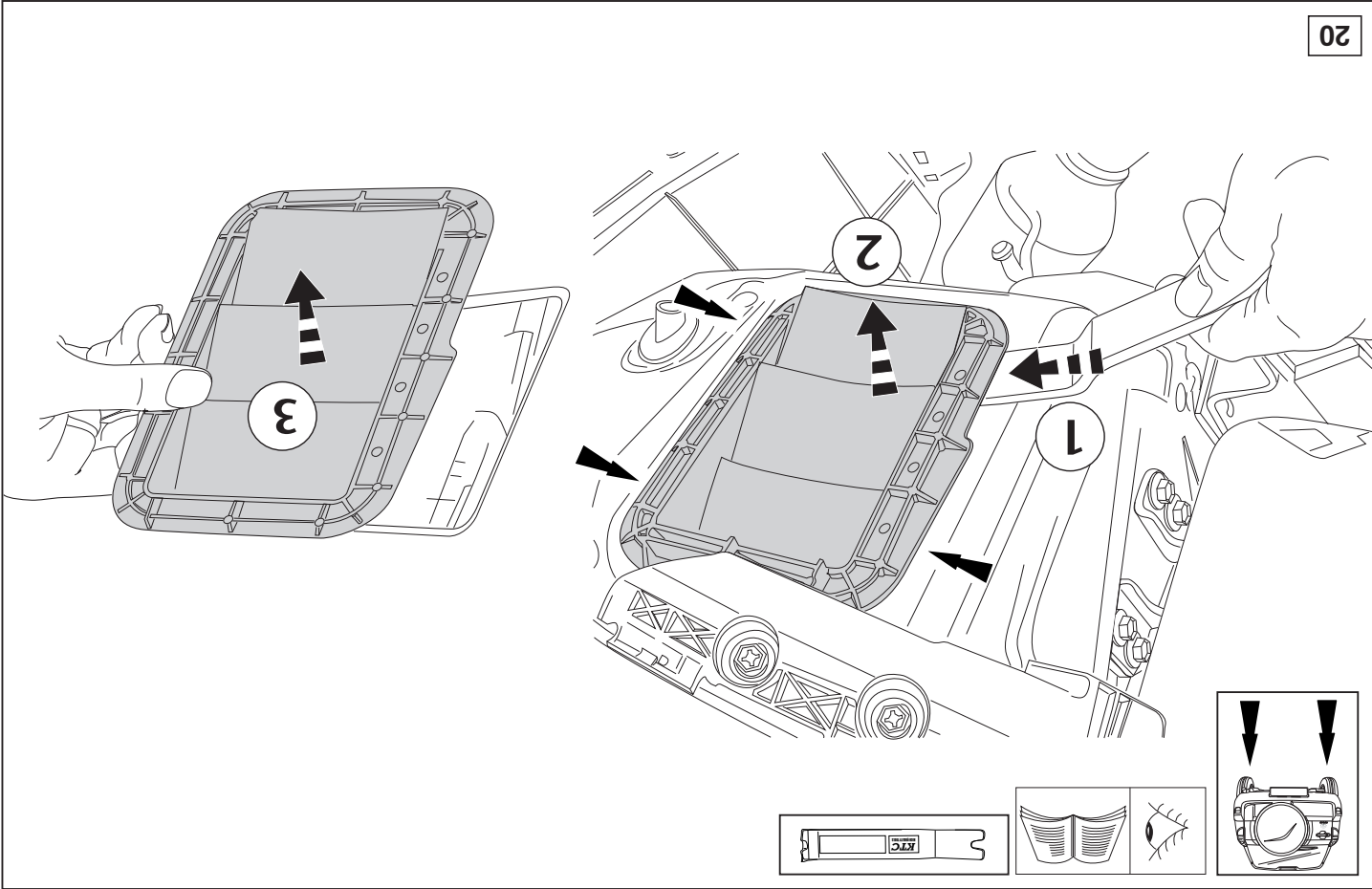

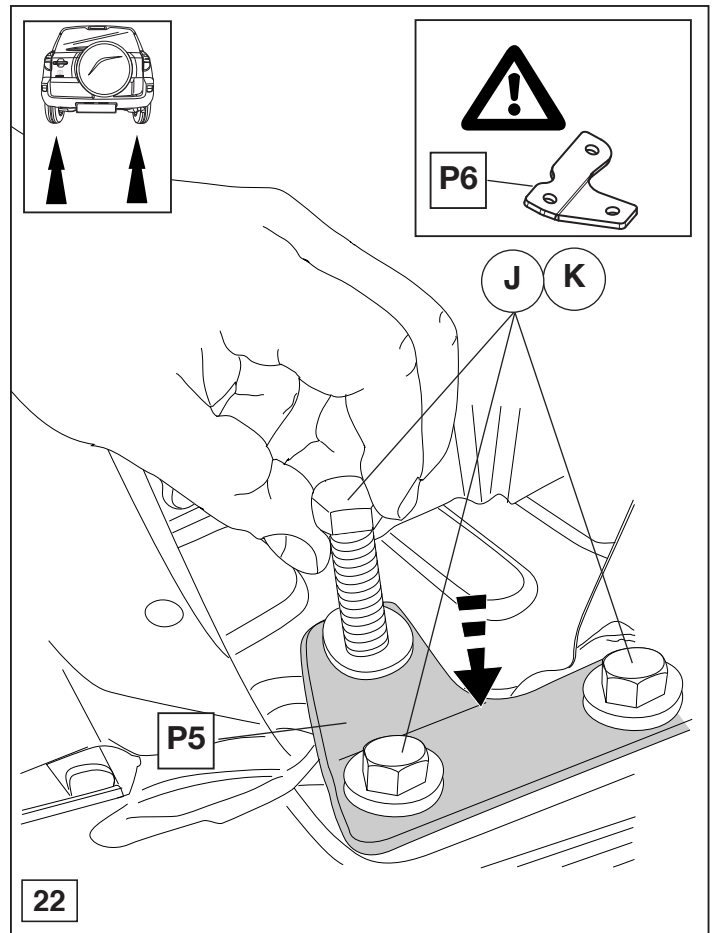
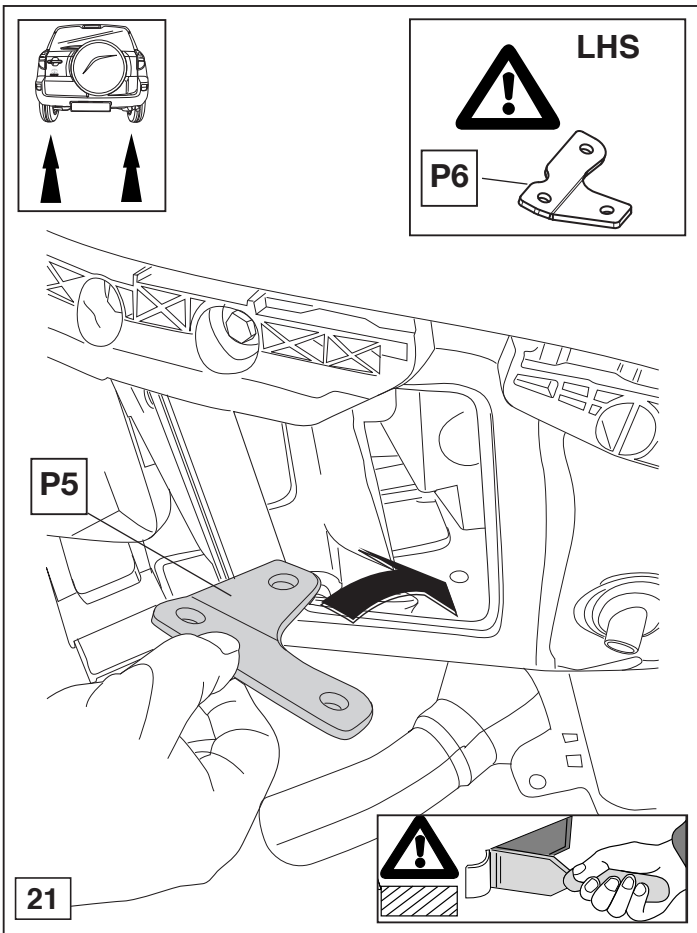

© 475470MN/08-06-2007/15

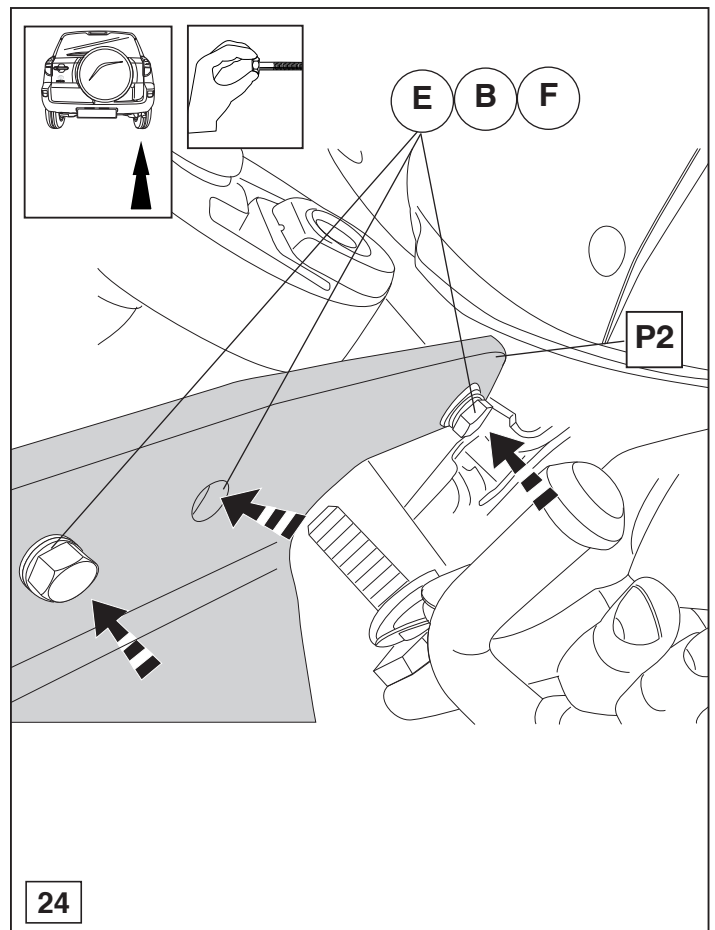
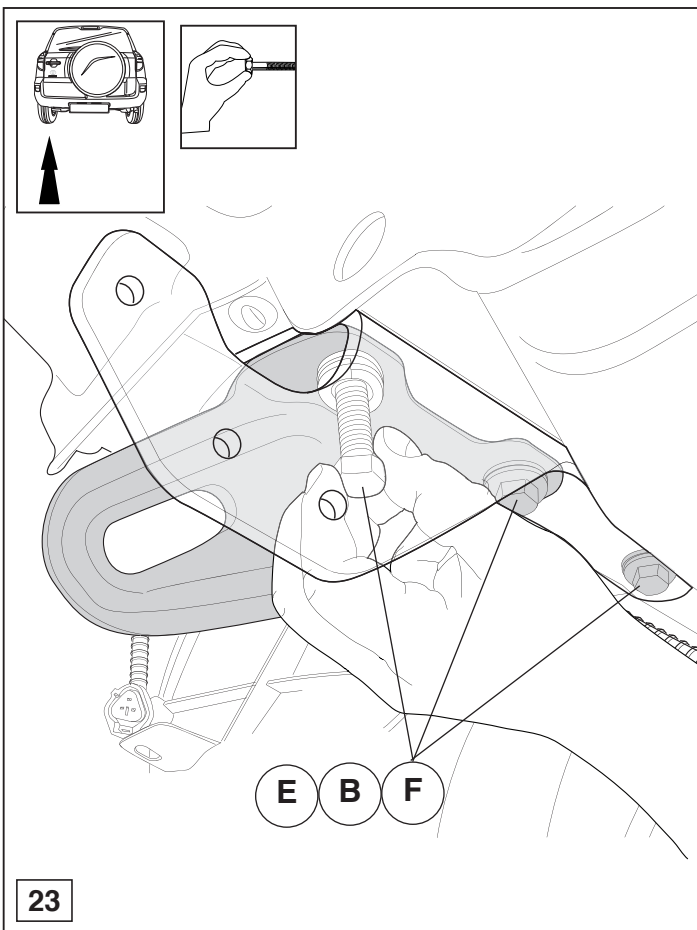

© 475470MN/08-06-2007/16