

bosal

**Инструкция
по монтажу тягово-сцепного
устройства шарового типа 5221 А
для автомобилей
Daewoo Kalos (3;5 дв.)
Chevrolet Aveo HB**

Daewoo Kalos (3,5 дв.)	2002/9—2009
Chevrolet Aveo HB	2003/11-...
	1200
	50
	20.6



462800,

« - »

18

т. (35363) 7-05-06

факс: (35363) 7-13-20

(495) 799-13-46

www.bosal-autoflex.ru

www.bosal.com

« - »	(8182) 22-48-15
"	" 8(8442) 98-74-98
"	" 8(343) 379-39-89, 373-42-73
"	" 8(343) 26-88-308
"	" 8(3952) 710-194
"	" 8(495) 777-54-59
"	" 8(495) 745-79-11
"	" 8(495) 788-95-97
"	" 8(495) 720-51-03
"	" 8(3532) 57-99-85
"	" 8-905-899-5012
"	" 8(383) 291-59-60
"	" 8(831) 279-53-24
"	" 8(3422) 98-27-20
"	" 8(342) 220-87-87
"	" 8-927-002-90-06
"	" 8(3462) 24-00-44
"	" 8(3842) 21-14-76
"	" 8-902-940-4151
"	" 8(3452) 32-22-12, 41-52-62
"	" 8-961-213-0278
"	" 8-917-347-1700
"	" 8(351) 269-44-75, 900-72-73
"	" 8(3512) 773-76-91

41.55-2005.

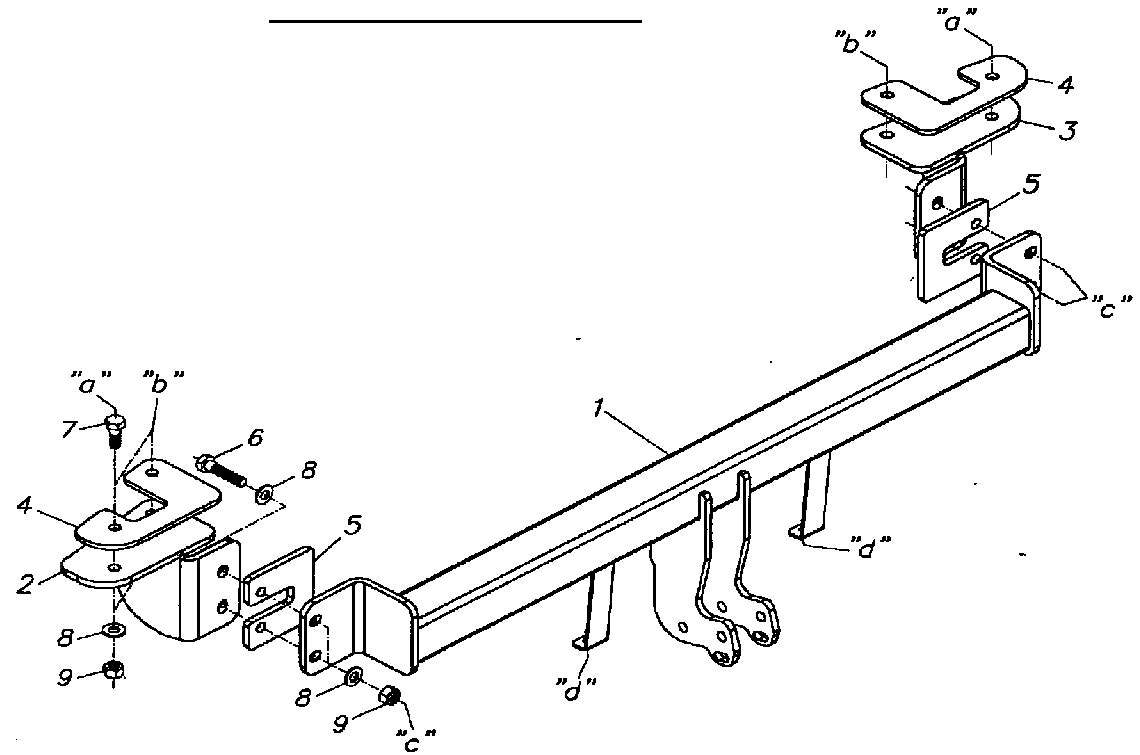

	1
	1
	1
	1
	1

	3
12 50	4
12 35	4
12 1.25x90	2
12x1.25 (/)	10
Ø13x24x2.5	15
(4)	2
(5)	2
	2
VH 0199	1
	1
	1
	1
	1
190	1
	1
	1

