



**Инструкция
по монтажу тягово-сцепного
устройства шарового типа 5253 А
для автомобилей
Chevrolet Epica**

	2007-...
	1300
	50
	18.7



« - - »:	" - - " (8182) 22-48-15
	" 8(8442) 98-74-98
	" 8(343) 379-39-89, 373-42-73
	" 8(343) 26-88-308
	" 8(3952) 710-194
	" 8(495) 777-54-59
	" 8(495)745-79-11
	" 8(495) 788-95-97
	" 8(495) 720-51-03
	" 8(3532) 57-99-85
	" 8-905-899-5012
	" 8(383) 291-59-60
	" 8(831) 279-53-24
	" 8(3422) 98-27-20
	" 8(342) 220-87-87
	" 8-927-002-90-06
	" 8(3462) 24-00-44
	" 8(3842) 21-14-76
	" 8-902-940-4151
	" 8(3452) 32-22-12, 41-52-62
	" 8-961-213-0278
	" 8-917-347-1700
	" 8(351) 269-44-75, 900-72-73
	" 8(3512) 773-76-91

462800,

« - - »
 18
 : (35363) 7-05-06
 / : (35363) 7-13-20
 (495) 785-66-07
www.bosal-autoflex.ru

.....

..... VIN

.....

.....

41.55-2005.

).

12 ..

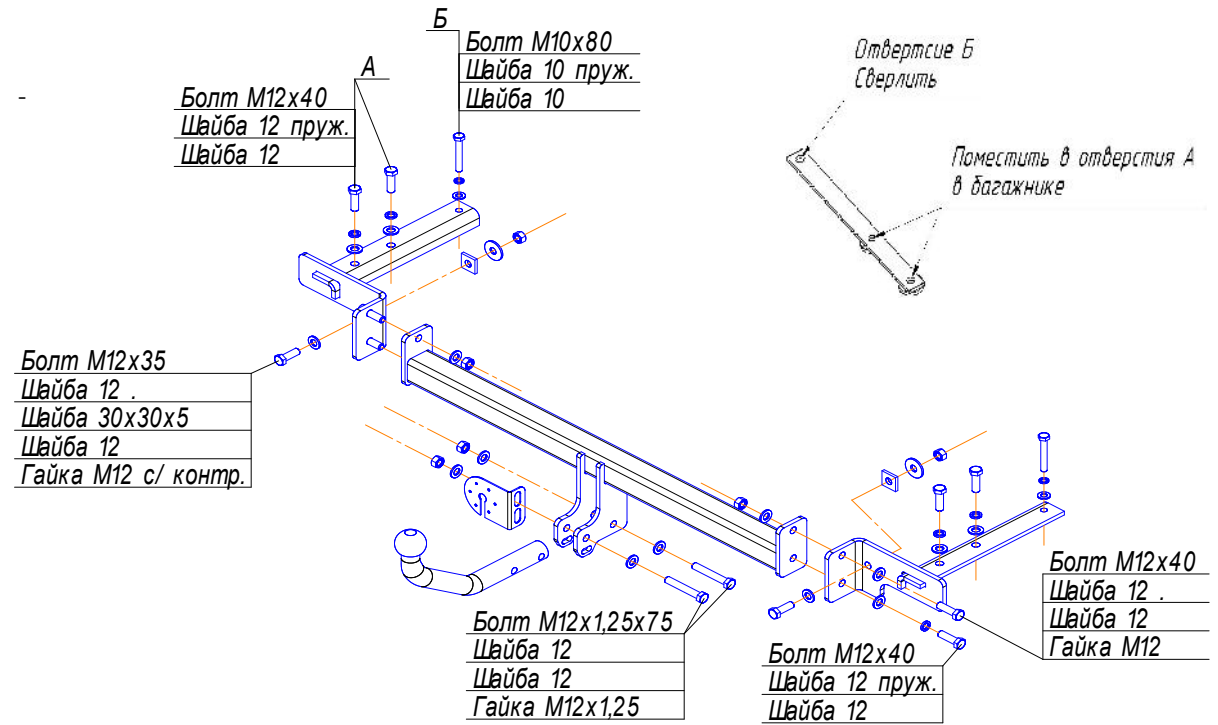

1			
2			
3			
4			
5			
6			
7			

	1
	1
	1
	1
	1

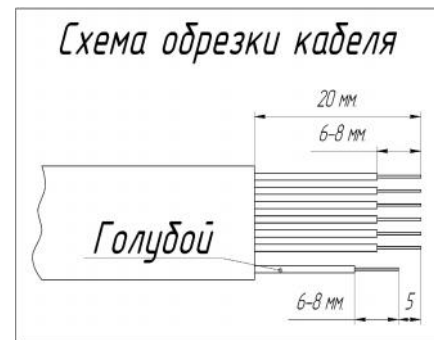

10 80	2
12 35	2
12 40	8
12 1,25 75	2
12	4
12 1,25	2
10	2
12	6
12	2
10	2
12	16
30 30 5	2
	3
	1
VH 0828	1
	1
	1
1,9	1
	1