

bosal

Инструкция по монтажу тягово-цепного устройства шарового типа 5506 А для автомобилей Honda HR-V

	1998/10—2006
	1200
	75
	20,75



462800,

« - »
18
: (35363) 7-05-06
/ : (35363) 7-13-20
(495) 799-13-46
www.bosal-autoflex.ru
www.bosal.com

« - »:	" (8182) 22-48-15
"	" 8(8442) 98-74-98
"	" 8(343) 379-39-89, 373-42-73
"	" 8(343) 26-88-308
"	" 8(3952) 710-194
"	" 8(495) 777-54-59
"	" 8(495) 745-79-11
"	" 8(495) 788-95-97
"	" 8(495) 720-51-03
"	" 8(3532) 57-99-85
"	" 8-905-899-5012
"	" 8(383) 291-59-60
"	" 8(831) 279-53-24
"	" 8(3422) 98-27-20
"	" 8(342) 220-87-87
"	" 8-927-002-90-06
"	" 8(3462) 24-00-44
"	" 8(3842) 21-14-76
"	" 8-902-940-4151
"	" 8(3452) 32-22-12, 41-52-62
"	" 8-961-213-0278
"	" 8-917-347-1700
"	" 8(351) 269-44-75, 900-72-73
"	" 8(3512) 773-76-91

41.55-2005.

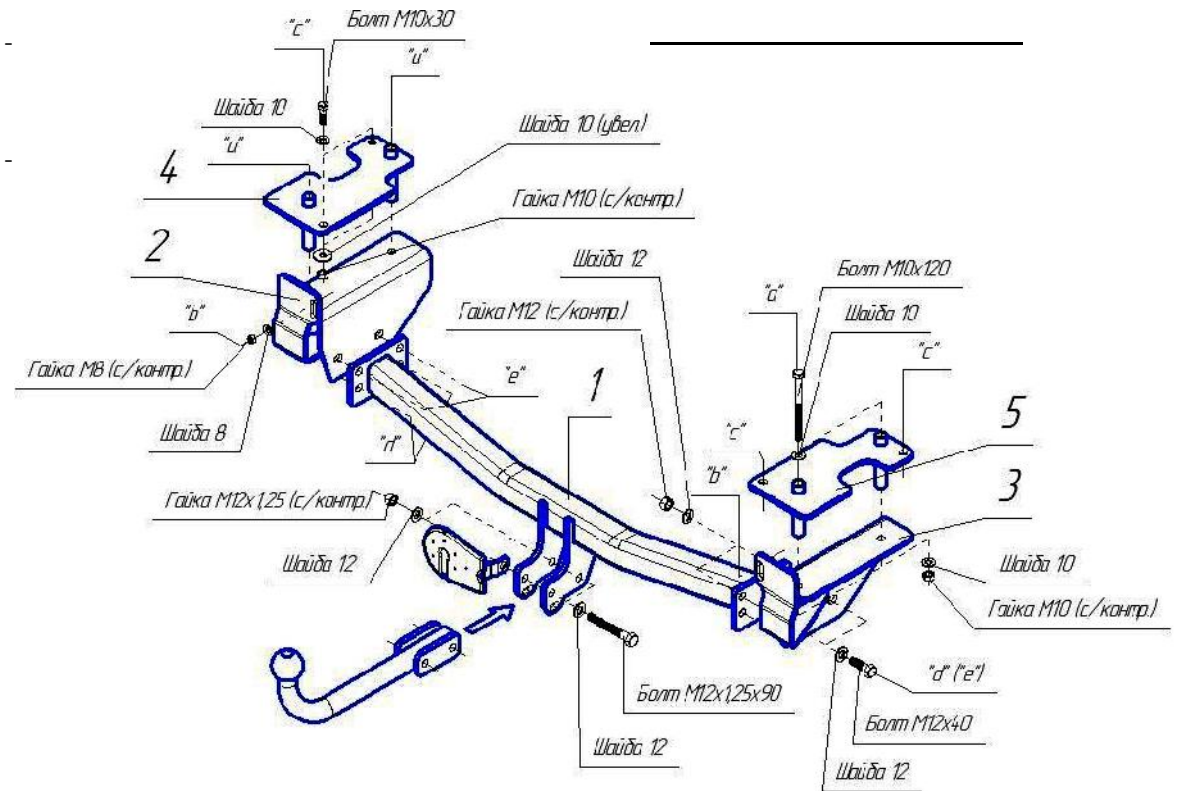

(
4 5.
« »
19
4 5
2 3
« » «b».
« »
10
(1)
«d» (
« »).

1			
2			
3			
4			
5			
6			

	1
	1
	1
	1
	1
	1
	1
	1

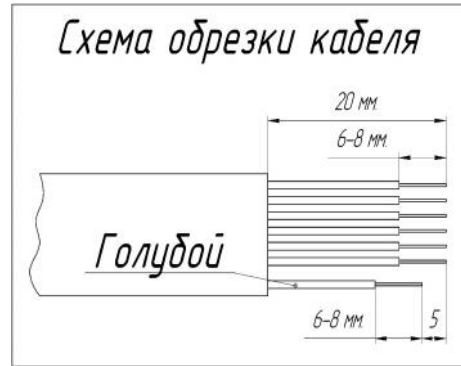

	3
10 30	4
10 120	4
12 40	4
12 90 1,25	2
8	2
12 1,25 /	2
12 /	4
10 /	8
8	2
10	12
12	12
10	4
	2
VH 0410	1
	1
	1
	1
190	1
	1
	1