

# bosal

**Инструкция  
по монтажу тягово-сцепного  
устройства шарового типа 6451 А  
для автомобилей  
SSANG YONG REXTON 2**

	2006 - ...
	1500
	75
	18,9



462800,

« - »

18

∴ (35363) 7-05-06

/ : (35363) 7-13-20

(495) 785-66-07

[www.bosal-autoflex.ru](http://www.bosal-autoflex.ru)

« - »:	" (8182) 22-48-15
"	" 8(8442) 98-74-98
"	" 8(343) 379-39-89, 373-42-73
"	" 8(343) 26-88-308
"	" 8(3952) 710-194
"	" 8(495) 777-54-59
"	" 8(495)745-79-11
"	" 8(495) 788-95-97
"	" 8(495) 720-51-03
"	" 8(3532) 57-99-85
"	" 8-905-899-5012
"	" 8(383) 291-59-60
"	" 8(831) 279-53-24
"	" 8(3422) 98-27-20
"	" 8(342) 220-87-87
"	" 8-927-002-90-06
"	" 8(3462) 24-00-44
"	" 8(3842) 21-14-76
"	" 8-902-940-4151
"	" 8(3452) 32-22-12, 41-52-62
"	" 8-961-213-0278
"	" 8-917-347-1700
"	" 8(351) 269-44-75, 900-72-73
"	" 8(3512) 773-76-91

41.55-2005.

2  
2  
6  
2

(80 25 6) " " (L=83) " "

" " " "  
12 = 79 Nm.

(1)  
" "

12 1,25 = 87 Nm.

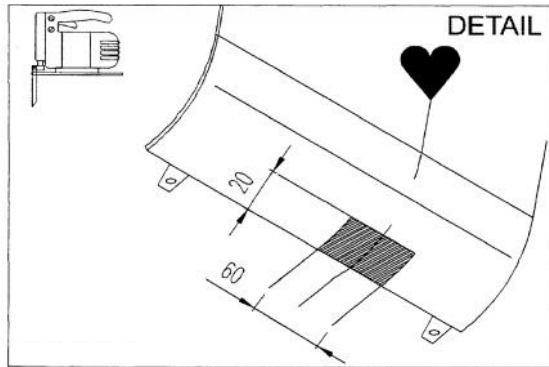

1			
2			
3			
4			
5			
6			
7			

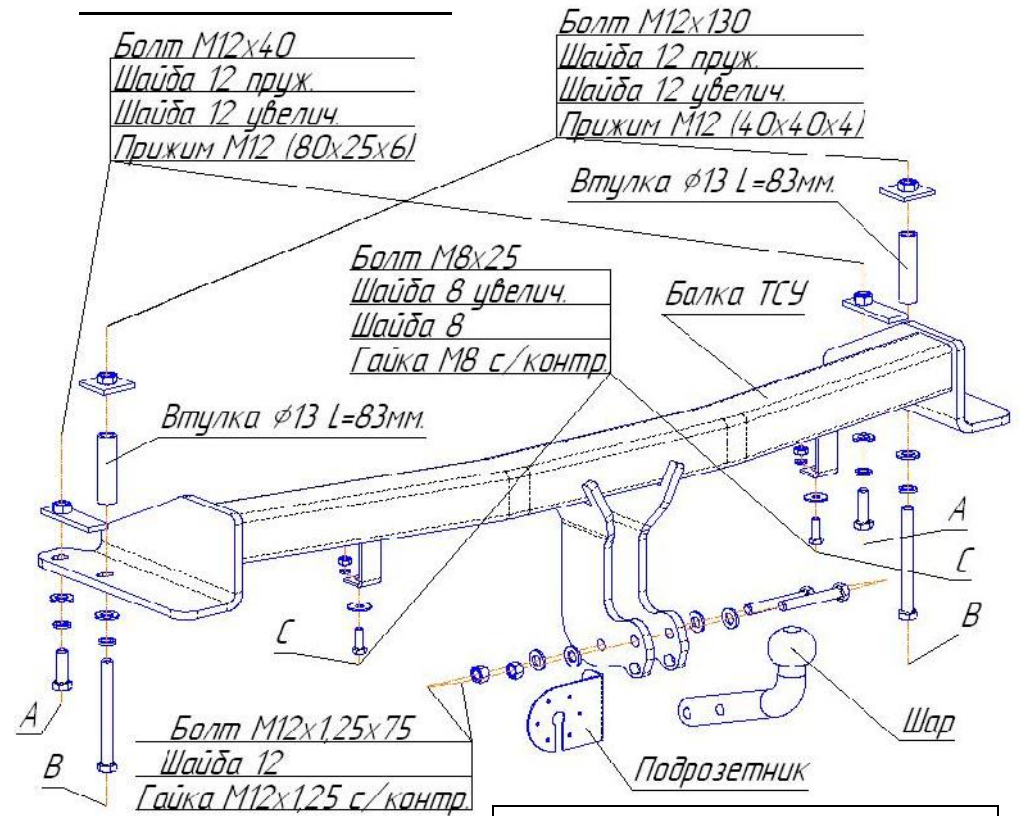
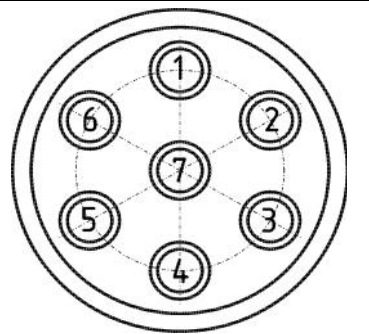

	1
	1
	1

	3
12 1,25 75	2
12 130	2
12 40	2
12 1,25 /	2
8 25	2
8 /	2
12	4
12	4
12	4
8	2
8	2
L=83	2
12 (40 40 4)	2
12 (80 25 6)	2
0145	1
	1
	1
	1
190	1
	1

Схема обрезки кабеля

