



**Инструкция
по монтажу тягово-цепного
устройства шарового типа 6703 А
для автомобилей
Kia Sportage**

| | |
|--|--------------|
| | 1995-1999/10 |
| | 1400 |
| | 75 |
| | 20,6 |



462800,

« - »
18
: (35363) 7-05-06
/ : (35363) 7-13-20
(495) 799-13-46

www.bosal-autoflex.ru
www.bosal.com

| | |
|-------|-------------------------------|
| « - » | (8182) 22-48-15 |
| " | " 8(8442) 98-74-98 |
| " | " 8(343) 379-39-89, 373-42-73 |
| " | " 8(343) 26-88-308 |
| " | " 8(3952) 710-194 |
| " | " 8(495) 777-54-59 |
| " | " 8(495) 745-79-11 |
| " | " 8(495) 788-95-97 |
| " | " 8(495) 720-51-03 |
| " | " 8(3532) 57-99-85 |
| " | " 8-905-899-5012 |
| " | " 8(383) 291-59-60 |
| " | " 8(831) 279-53-24 |
| " | " 8(3422) 98-27-20 |
| " | " 8(342) 220-87-87 |
| " | " 8-927-002-90-06 |
| " | " 8(3462) 24-00-44 |
| " | " 8(3842) 21-14-76 |
| " | " 8-902-940-4151 |
| " | " 8(3452) 32-22-12, 41-52-62 |
| " | " 8-961-213-0278 |
| " | " 8-917-347-1700 |
| " | " 8(351) 269-44-75, 900-72-73 |
| " | " 8(3512) 773-76-91 |

41.55-2005.

« »

« »

12 90,

L=58

53

Ø18

L=53

a

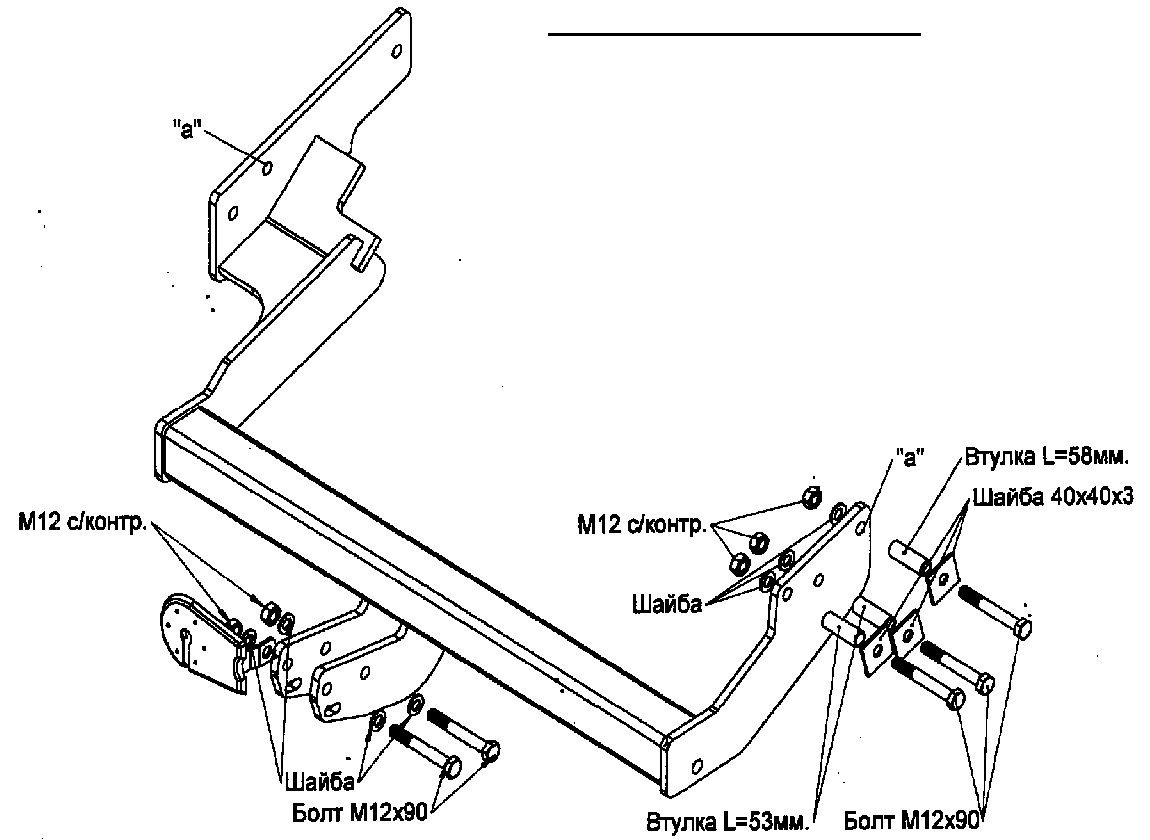

| | |
|--|---|
| | 1 |
| | 1 |
| | 1 |

| | |
|-------------|----|
| | 3 |
| 12 / | 8 |
| 12 | 10 |
| 12 40x40x4 | 6 |
| 12 90 | 8 |
| L - 53 | 4 |
| L - 58 | 2 |
| | 2 |
| VH 0701 () | 1 |
| | 1 |
| | 1 |
| | 1 |
| 190 | 1 |
| | 1 |

| | | | |
|---|--|--|--|
| | | | |
| 1 | | | |
| 2 | | | |
| 3 | | | |
| 4 | | | |
| 5 | | | |
| 6 | | | |
| 7 | | | |

Схема обрезки кабеля

