

bosal

**Инструкция
по монтажу тягово-сцепного
устройства шарового типа 6732 А
для автомобилей
Kia Cerato Sedan, НВ**

	2004-...
	1100
	60
	13,6



462800,

« - »
18
: (35363) 7-05-06
/ : (35363) 7-13-20
(495) 799-13-46
www.bosal-autoflex.ru
www.bosal.com

« - »	(8182) 22-48-15
"	" 8(8442) 98-74-98
"	" 8(343) 379-39-89, 373-42-73
"	" 8(343) 26-88-308
"	" 8(3952) 710-194
"	" 8(495) 777-54-59
"	" 8(495)745-79-11
"	" 8(495) 788-95-97
"	" 8(495) 720-51-03
"	" 8(3532) 57-99-85
"	" 8-905-899-5012
"	" 8(383) 291-59-60
"	" 8(831) 279-53-24
"	" 8(3422) 98-27-20
"	" 8(342) 220-87-87
"	" 8-927-002-90-06
"	" 8(3462) 24-00-44
"	" 8(3842) 21-14-76
"	" 8-902-940-4151
"	" 8(3452) 32-22-12, 41-52-62
"	" 8-961-213-0278
"	" 8-917-347-1700
"	" 8(351) 269-44-75, 900-72-73
"	" 8(3512) 773-76-91

41.55-2005.

“a” “b”

“c”

8 25,

Болт М10х30
Шайба φ10 пруж
Шайба φ10 уделич.

Болт М18х25
Шайба φ8

Болт М12х1,25х100
Гайка М12х1,25
Шайба φ12

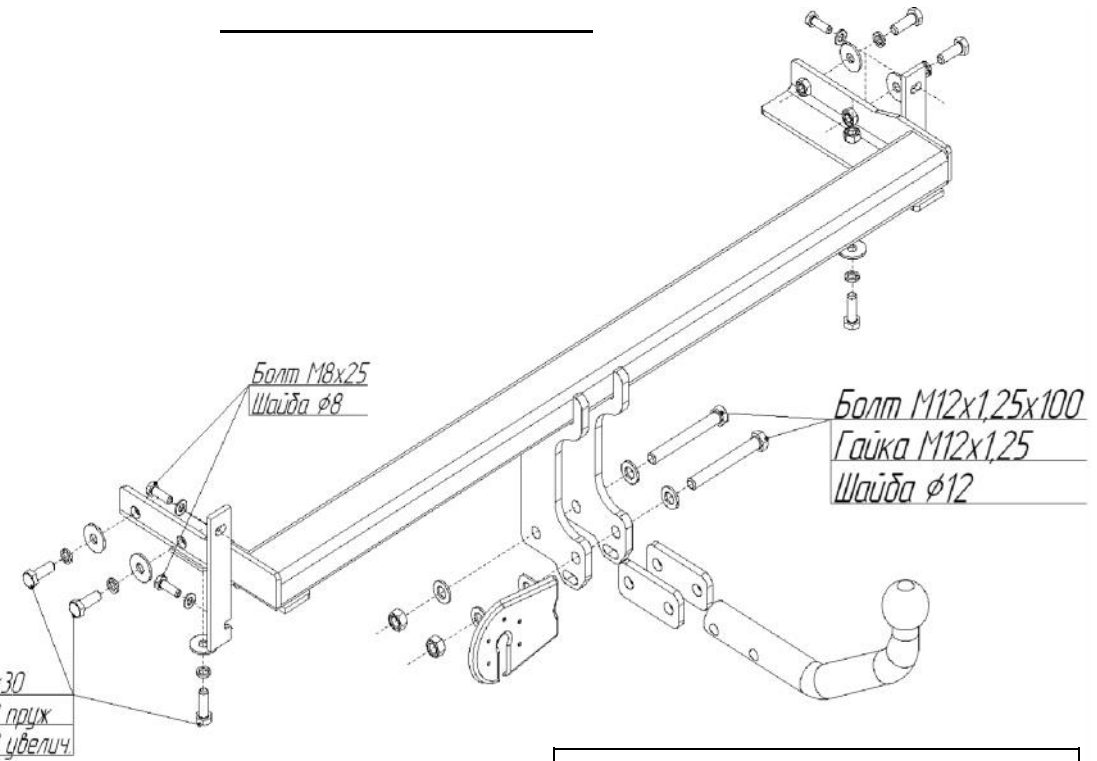

(12 1,25 90).

	1 .
	1 .
	1 .

	3 .
12 1,25 100	2 .
10 30	6 .
8 25	4 .
12 1,25 /	2 .
10	6 .
10	6 .
12	4 .
8	4 .
	2 .
VH 0828	1 .
	1 .
	1 .
	1 .
190	1 .
	2 .
	1 .

1			
2			
3			
4			
5			
6			
7			

