

bosal

Инструкция по монтажу тягово-цепного устройства шарового типа 6748 А для автомобилей **Kia Rio sedan**

	2011 -...
	1000
	50
	14,3



462800,

« - »
18
: (35363) 7-05-06
/ : (35363) 7-13-20
(495) 785-66-07
www.bosal-autoflex.ru

« - »	(8182) 22-48-15
" - "	" 8(8442) 98-74-98
" - "	" 8(343) 379-39-89, 373-42-73
" - "	" 8(343) 26-88-308
" - "	" 8(3952) 710-194
" - "	" 8(495) 777-54-59
" - "	" 8(495) 745-79-11
" - "	" 8(495) 788-95-97
" - "	" 8(495) 720-51-03
" - "	" 8(3532) 57-99-85
" - "	" 8-905-899-5012
" - "	" 8(383) 291-59-60
" - "	" 8(831) 279-53-24
" - "	" 8(3422) 98-27-20
" - "	" 8(342) 220-87-87
" - "	" 8-927-002-90-06
" - "	" 8(3462) 24-00-44
" - "	" 8(3842) 21-14-76
" - "	" 8-902-940-4151
" - "	" 8(3452) 32-22-12, 41-52-62
" - "	" 8-961-213-0278
" - "	" 8-917-347-1700
" - "	" 8(351) 269-44-75, 900-72-73
" - "	" 8(3512) 773-76-91

41.55-2005.

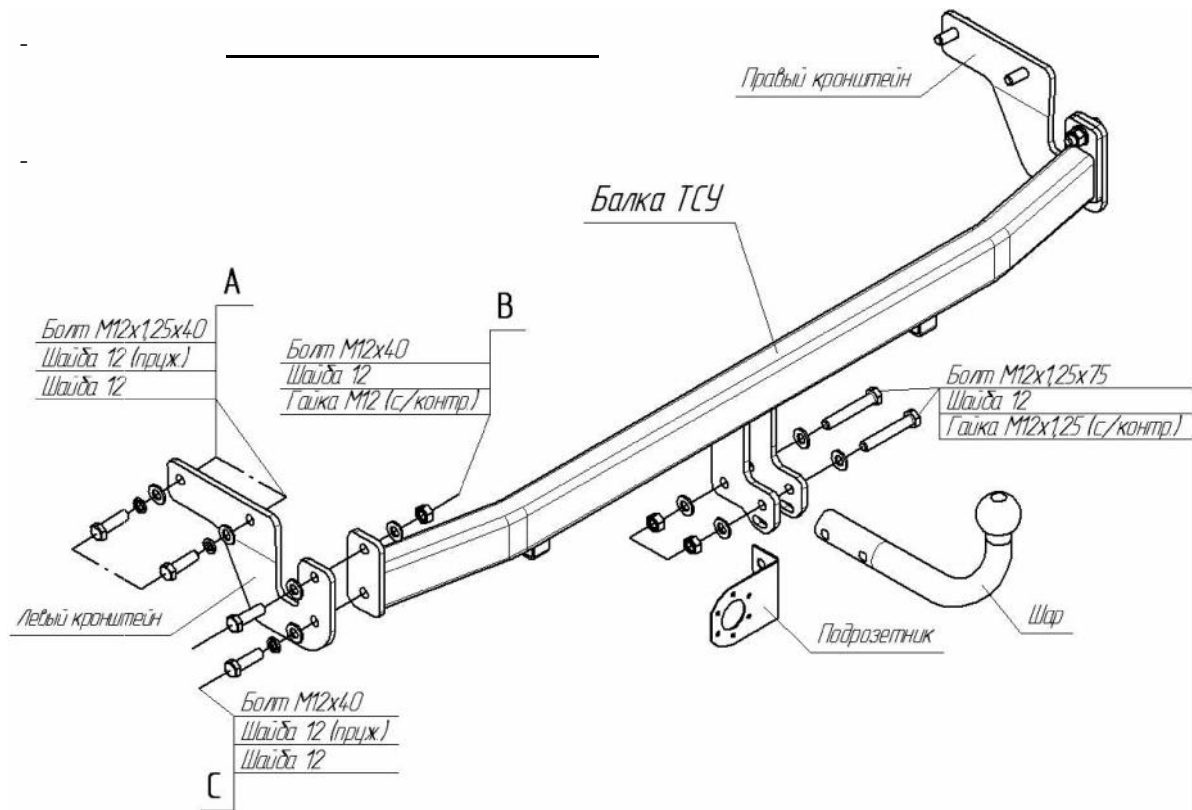

(
« »
12 1,25 40.
« » « » (
): 12—79Nm.

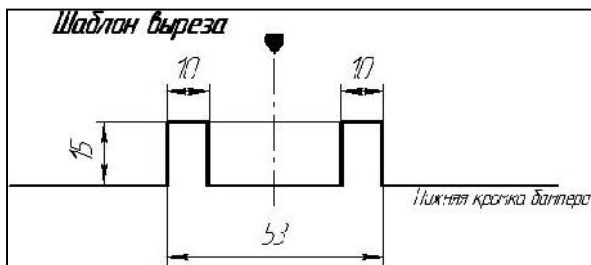

	1
	1
	1
	1
	1

		2
12 1,25 75		2
12 40		4
12 1,25 40		4
12 /		2
12 1,25 /		2
12		6
12		14
VH 0840		1
		1
		1
	1	1
		1

