

# bosal

**Инструкция  
по монтажу тягово-сцепного  
устройства шарового типа 7601 А  
для автомобилей  
Chery Amulet**

|  |          |
|--|----------|
|  | 2006-... |
|  |          |
|  | 1500     |
|  | 75       |
|  | 14.3     |



462800,

« - »  
: (35363) 7-05-06  
/ : (35363) 7-13-20  
(495) 785-66-07

[www.bosal-autoflex.ru](http://www.bosal-autoflex.ru)

18

|       |                               |
|-------|-------------------------------|
| « - » | »                             |
| "     | " (8182) 22-48-15             |
| "     | " 8(8442) 98-74-98            |
| "     | " 8(343) 379-39-89, 373-42-73 |
| "     | " 8(343) 26-88-308            |
| "     | " 8(3952) 710-194             |
| "     | " 8(495) 777-54-59            |
| "     | " 8(495) 745-79-11            |
| "     | " 8(495) 788-95-97            |
| "     | " 8(495) 720-51-03            |
| "     | " 8(3532) 57-99-85            |
| "     | " 8-905-899-5012              |
| "     | " 8(383) 291-59-60            |
| "     | " 8(831) 279-53-24            |
| "     | " 8(3422) 98-27-20            |
| "     | " 8(342) 220-87-87            |
| "     | " 8-927-002-90-06             |
| "     | " 8(3462) 24-00-44            |
| "     | " 8(3842) 21-14-76            |
| "     | " 8-902-940-4151              |
| "     | " 8(3452) 32-22-12, 41-52-62  |
| "     | " 8-961-213-0278              |
| "     | " 8-917-347-1700              |
| "     | " 8(351) 269-44-75, 900-72-73 |
| "     | " 8(3512) 773-76-91           |

1. ( )  
2.  
3.  
4. 1000  
90 /  
1. « - » 12  
8.8.  
2.  
3.

|                 |
|-----------------|
| ..... : .....   |
| ..... VIN ..... |
| .....           |
| .....           |

41.55-2005.

2

10 40

« ».

10 30

« ».

« ».

« ».

« » « »

8 30.

«D»

« »

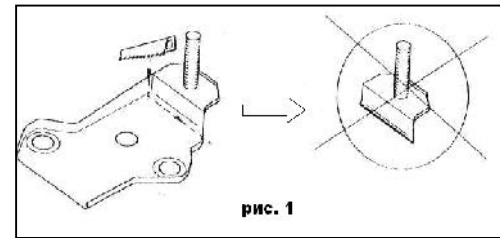
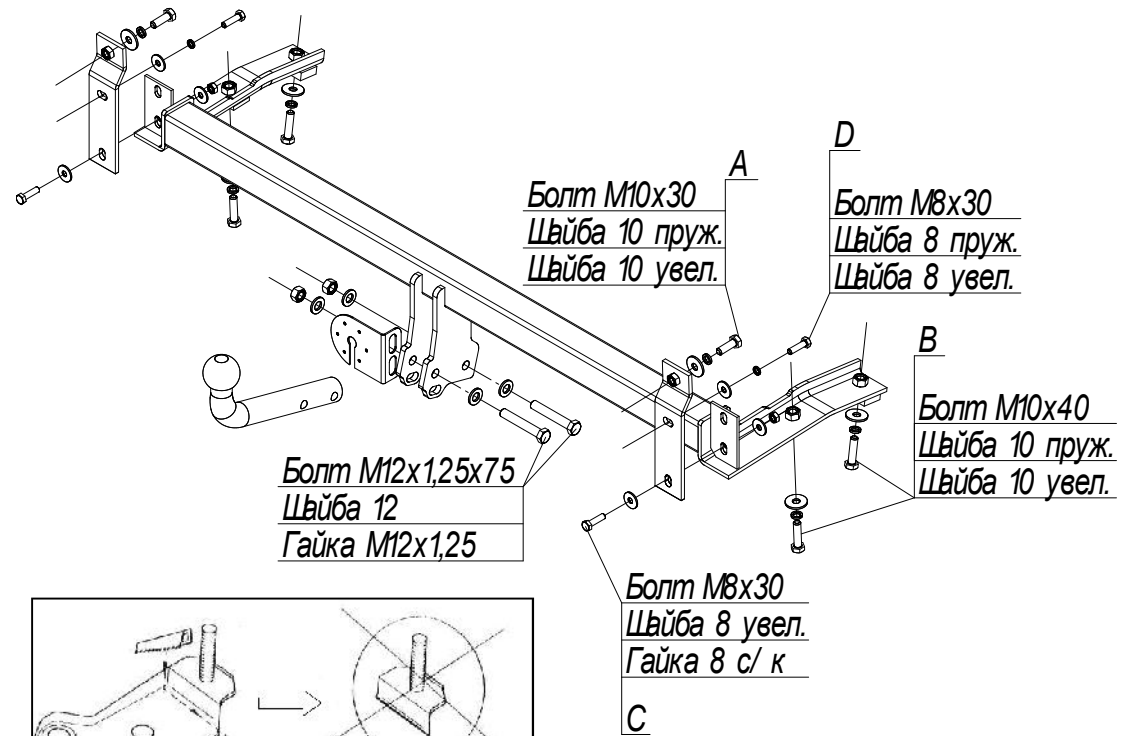

|  |   |
|--|---|
|  | 1 |
|  | 1 |
|  | 1 |

|   |  |  |  |
|---|--|--|--|
|   |  |  |  |
| 1 |  |  |  |
| 2 |  |  |  |
| 3 |  |  |  |
| 4 |  |  |  |
| 5 |  |  |  |
| 6 |  |  |  |
| 7 |  |  |  |

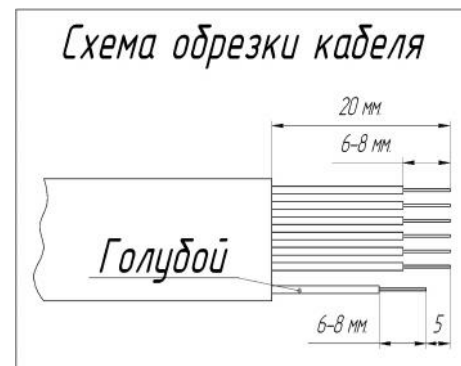

|            |   |
|------------|---|
|            | 3 |
| 8 30       | 4 |
| 10 30      | 2 |
| 10 40      | 4 |
| 12 1,25 75 | 2 |
| 8 /        | 2 |
| 12 1,25 /  | 2 |
| 8          | 2 |
| 10         | 6 |
| 8          | 6 |
| 10         | 6 |
| 12         | 4 |
| VH0164     | 1 |
|            | 2 |
|            | 1 |
|            | 1 |
|            | 1 |
| 190        | 1 |
|            | 1 |
|            | 1 |